



# Spare Parts Catalog

6 WG 190 (Current date: 23.11.2012)

Material number: 4657.026.105

ZF Friedrichshafen AG

Hauptverwaltung

80038 Friedrichshafen

Deutschland

Telefon: +49 7541 77-0

Telefax: +49 7541 77-908000

[www.zf.com](http://www.zf.com)

zuständiges Werk:

Passau

# Notes relating to the spare parts catalog

## Setup of the spare parts catalog

- Cover sheet
- Technical Cover (only in SDM print)
- Overview of figures
- Figure
- Associated parts list
- Next figure
- Associated parts list
- ...

## Figure and parts list



## Overview of figures

Bildtafel Figure	Sachnummer Product number	Benennung (Description)	Technische Info Technical info	Description (Benennung)	Menge Quantity	Einheit Unit
068.08.17	1316.170.001	AUSLEGER	WL	SHIFT TURRET	1	Stk
068.08.06	1316.170.031	DECKEL	WL*H-H *VM	COVER	1	Stk
068.08.14	1316.170.808	DECKEL	WL*AUSL+GEH*H-H*HF160N	COVER	1	Stk
08	1316.170.441	ANSCHLUSSTEILE	WL*NG-VORB*RG-SCHL*168N *BAJONETT	CONNECTING PARTS	1	Stk

The "gap" indicates that there is no separate graphics panel (poster) for this assembly  
The parts of this assembly are shown with the same mid-section number on the figure

### 1 Positions and subpositions

Pos.	Sachnummer Product number	Benennung (Description)	Technische Info Technical info	Description (Benennung)	Menge Quantity	Einheit Unit
0370	1315.201.054	RUECKLAUFBOLZEN	KPL.16S151*SG*L= 79	REV.IDLER SHAFT	1	Stk
/0120	0631.329.293	SPANNSTIFT		SLOT. PIN	1	Stk

Positions marked with "/" are the individual items of a completion  
For example: Position 0370 contains a centering pin with the position /0120

### 2 Combinations with standardized parts

Pos.	Sachnummer Product number	Benennung (Description)	Technische Info Technical info	Description (Benennung)	Menge Quantity	Einheit Unit
0630		VERSCHL.SCHR.		SCREW PLUG	1	Stk
	0636.302.067	VERSCHL.SCHR.		SCREW PLUG	1	Stk
	0634.801.249	DICHTRING	A 26 X 31	SEALING RING	1	Stk

The parts list shows the components included in the combination of standardized parts

### 3 Depiction of position/item number on the figure and in the parts list

01.620 - on the figure      01 relates to the assembly in which the position is included. Due to program-related reasons, it is shown on the figure.

0620 - in the parts list

Pos.	Sachnummer Product number	Benennung (Description)	Technische Info Technical info	Description (Benennung)	Menge Quantity	Einheit Unit
0620	0732.040.736	DRUCKFEDER		COMPRESSION SPRING	1	Stk

### 4 \*-Positions

Positions marked with an \* are optional i.e. inclusion in the parts list is not mandatory.  
The following note is shown on the figure

je nach Stücklistenausführung  
depending on spec. number  
\*  
suivant la nomenclature  
secondo la distinta base

### 5 Parts, dotted display

Parts with dotted display on the figure are only used for orientation of other parts



Pos.	Information	Amendment number
	CUSTOMER: BRJANSKIJ ARSENAL	
	1.PERFORMANCE CALC.: 4657 707 001	
	VEHICLE DESIGNATION: GRADER GS18	
	WEIGHT LOADED: 13,50 TO	
	ENGINE: YAMZ 236	
	ENGINE POWER: 184,0 KW	
	SPEED: 2.000 DRZ	
	INPUT TORQUE: 1.080 NM	
	SPEED: 1.300 DRZ	
	TYRE RADIUS DYN: 0,624 M	
	AXLE RATIO: 14,100	
	MAX. SPEED: 51,0 KM/H	
	PRODUCT DESCRIPTION: ZF-ERGOPOWER TRANSMISSION	
	TRANSMISSION TYPE 6 WG 190	
	DROP CENTER DISTANCE: 540 MM	
	VEHICLE: GRADER	
	1. GEAR FORWARD: 5,562	
	2. GEAR FORWARD: 3,615	
	3. GEAR FORWARD: 2,255	
	4. GEAR FORWARD: 1,466	
	5. GEAR FORWARD: 0,942	
	6. GEAR FORWARD: 0,613	
	1. GEAR REVERSE: 5,274	
	2. GEAR REVERSE: 2,138	
	3. GEAR REVERSE: 0,894	
	NUMBER OF PULSES ENGIN: 4	
	NUMBER OF PULSES TURB: 54	
	NUMBER OF PULSES MRK: 55	
	NUMBER OF PULSES OUTP.: 46	
	CONVERTER: W 340	
	CONVERTER PART NR: 4168034117	
	LOCK-UP CLUTCH: WITHOUT	



Pos.	Information	Amendment number
	STALL TORQUE RATIO: 1,77	
	TORQUE CONVERTER ABSORP 271 NM	
	STATOR FREEWHEEL: WITHOUT	
	ENGINE INPUT: REMOTE MOUNTED VIA JOINT SHAFT	
	INPUT FLANGE: D 120 8 X DIA. 10,1	
	OUTPUT: STANDARD	
	OUTPUT CONVERTER SIDE: WITHOUT AXLE DISCONNECT	
	OUTPUT FLANGE CONVERTER D 180 CT 8 X DIA14 X 1,5 X 45	
	AXIAL DISPLACEBILITY: WITHOUT	
	OUTPUT PTO SIDE: WITHOUT PARKING BRAKE	
	OUTPUT FLANGE PTO SIDE: D 180 8 X DIA 14 X 1,5 X 45	
	PTO - DISCONNECTION: WITHOUT	
	1.PTO FLANGE: SAE C 2/4 HOLE	
	DRIVER / PROFILE: SAE C 12/24 DP 14 T	
	GEAR CHANGE CONTROL: ZF-ERGOSHIFT/ PROP VALVE	
	VOLTAGE: 24 VOLT	
	SPEED CONTROL: CONNECTION VIA EST	
	OIL LEVEL TUBE: MOUNTED ON CONVERTER SIDE	
	OIL DIPSTICK: SHORT STRAIGHT	
	FILTER INSTALLATION: DIRECT MOUNTED	
	PRES. DROP SWITCH: CLOSING SWITCH	
	EMERGENCY STEERING PUMP WITHOUT	
	OIL TEMPERATURE SENSOR: WITH (WITHOUT GAUGE)	
	GEARBOX BREATHER: WITH	
	ELECTRIC PARTS ORDER: INCLUDED IN SCOPE OF SUPPLY	
	GROUP LOOSE PARTS: 4657 183 158	
	CONTROL UNIT: EST 37A	
	GEAR SELECTOR: VTS 3	
	DISPLAY: FOR SEPERATE MOUNTING	
	WIRING: WITH	
	OIL CAPACITY: CA. 27 LITRE	
	GEARBOX OIL FILLING: WITHOUT	



Pos.	Information	Amendment number
	OEL-CLASS: OIL SPECIFICATION TE ML 03	
	PRIMER PAINT: RED RAL 3009	
	DOCUMENTATION GEAR BOX: -----	
	SECTION DRAWING: 4657 500 012	
	INSTALLATION DRAWING: 4657 626 105	
	GEARBOX DIAGRAM: 4657 700 043	
	OIL CIRCUIT DIAGRAMM: 4657 700 144	
	INSTAL. INSTRUCTIONS: 0000 702 271	
	DRAWING 6009 665 002	
	DRAWING GEAR SEL. 1: 6006 635 005	
	CONNECTION DIAGRAMM: 6006 700 529	
	WIRING DIAGRAMM: 6029 701 955	
	CONNECTION DIAGRAMM: 6029 701 951	
	DRAWING DISPLAY: 6007 603 047	

# Assembly group overview

Material number: 4657.026.105

6 WG 190 (Current date: 23.11.2012) /

Page 1 from 2



Graphics	Pos.	Material number	Name	Quantity	Amend. no.	Techn. Info.
465713004500	270	4657.130.045	ENGINE CONNECTION	1		
465613040400	280	4656.130.404	ENGINE CONNECTION	1		
416603408000	500	4166.034.080	CONVERTER	1		
465710203000	30	4657.102.030	INPUT	1		
465710106201	10	4657.101.062	GEARBOX HOUSING	1		
465710140800	20	4657.101.408	GEARBOX HOUSING	1		
465717103000	350	4657.171.030	COUPLING	1		
465717202700	360	4657.172.027	COUPLING	1		
465717302900	370	4657.173.029	COUPLING	1		
465717403800	380	4657.174.038	COUPLING	1		
465717501400	390	4657.175.014	COUPLING	1		
465717601700	400	4657.176.017	COUPLING	1		
465710301000	50	4657.103.010	OUTPUT	1		
465710342900	60	4657.103.429	OUTPUT	1		
465710344200	70	4657.103.442	OUTPUT	1		
465715400400	340	4657.154.004	POWER TAKE-OFF	1		

# Assembly group overview

Material number: 4657.026.105

6 WG 190 (Current date: 23.11.2012) /

Page 2 from 2



Graphics	Pos.	Material number	Name	Quantity	Amend. no.	Techn. Info.
465710601200	110	4657.106.012	GEAR SHIFT SYSTEM	1		
465710640720	115	4657.106.407	GEAR SHIFT SYSTEM	1		
465615901921	120	4656.159.019	GEAR SHIFT SYSTEM	1		
465712300300	225	4657.123.003	CONTROL UNIT	1		
465612000300	190	4656.120.003	PRESSURE REGULATOR	1		
465712200500	220	4657.122.005	PRESSURE OIL PUMP	1		
465613700400	310	4656.137.004	EMERGENCY STEERING PUMP	1		
465710700300	130	4657.107.003	SPEEDO	1		
465712500200	250	4657.125.002	INDTRANSMITTER	1		
465712400300	240	4657.124.003	TEMPERATURE SENSOR	1		
465613801500	330	4656.138.015	FILTER	1		
465713100400	290	4657.131.004	FILLER NECK	1		
465718315800	495	4657.183.158	LOOSE PARTS	1		

# Plant

Page 1 from 1

Material number: 4657.026.105

Plant: 465713004500

Material-assembly-group-no: 4657.130.045

6 WG 190 (Current date: 23.11.2012) /

ENGINE CONNECTION

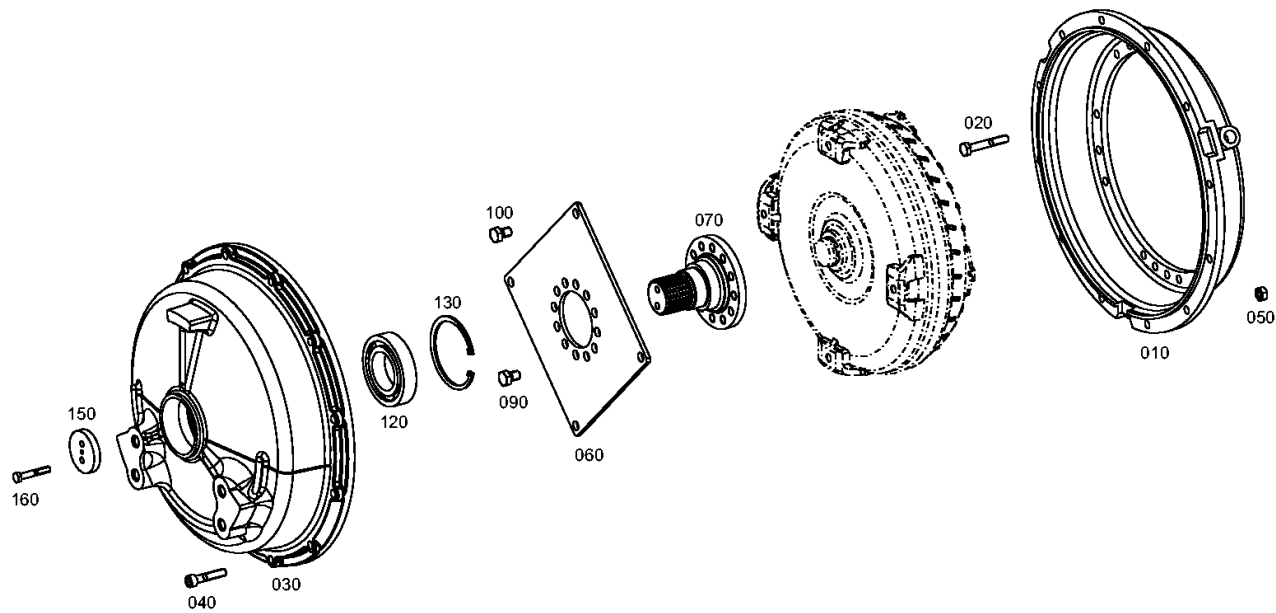



# Parts list

Page 1 from 1

Material number: 4657.026.105

Plant: 465713004500

Material-assembly-group-no: 4657.130.045

6 WG 190 (Current date: 23.11.2012) /



Pos.	Material number	Customer material	Name	Quantity	ME	Amend. no.	Techn. Info.	Weight	Rep kit	Alternative material
10	4656.330.008		CONVERTER BELL	1				9,140		
20	0636.100.713		HEXAGON BOLT	18			M10X65	0,000		
30	4657.330.037	9304580	COVER	1				19		
40	0636.101.115	SA 8320-03200	CAP SCREW	12			M10X50	38		
50	0637.006.125	8900124986	HEXAGON NUT	12			M10	10		
60	4657.330.004	SA 8320-26780	DIAPHRAGM	1				2,560		
70	4657.330.053	9305013	INPUT SHAFT	1		K01306/0610	Z=24	2,350		
90	0636.016.221	SA 8320-03570	HEXAGON BOLT	12			M12X18	30		
100	0636.016.221	SA 8320-03570	HEXAGON BOLT	4			M12X18	30		
120	0750.116.221	9304583	BALL BEARING	1			55,000X100,000X21,000	0,608		
130	0630.532.157	9304584	V-RING	1				40		
150	4627.303.027	ZM 2126110	WASHER	1				0,210		
160	0636.010.741	9301446	HEXAGON BOLT	2			M8X50	25		

# Plant

Page 1 from 1

Material number: 4657.026.105

Plant: 465613040400

Material-assembly-group-no: 4656.130.404

6 WG 190 (Current date: 23.11.2012) /

ENGINE CONNECTION

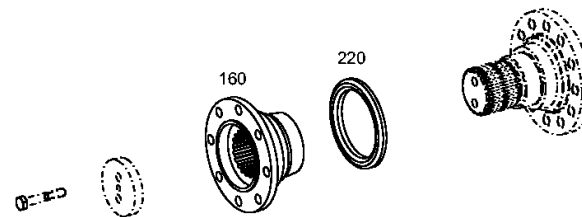

# Parts list

Page 1 from 1

Material number: 4657.026.105

6 WG 190 (Current date: 23.11.2012) /

Plant: 465613040400

Material-assembly-group-no: 4656.130.404



Pos.	Material number	Customer material	Name	Quantity	ME	Amend. no.	Techn. Info.	Weight	Rep kit	Alternative material
160	4644.330.128	ZM 2282671	INPUT FLANGE	1				1,460		
220	4657.330.042	9302029	SCREEN SHEET	1		K00197/0210	S=2,0	90		

# Plant

Page 1 from 1

Material number: 4657.026.105

Plant: 416603408000

Material-assembly-group-no: 4166.034.080

6 WG 190 (Current date: 23.11.2012) /

CONVERTER

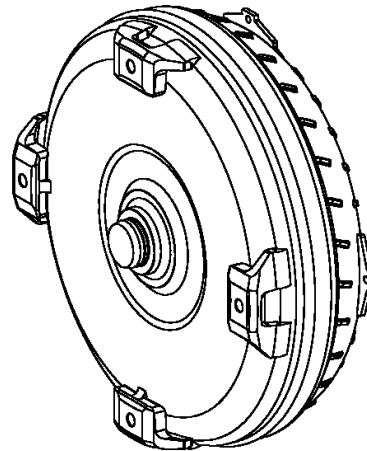

010

# Parts list

Page 1 from 1

Material number: 4657.026.105

6 WG 190 (Current date: 23.11.2012) /

Plant: 416603408000

Material-assembly-group-no: 4166.034.080



Pos.	Material number	Customer material	Name	Quantity	ME	Amend. no.	Techn. Info.	Weight	Rep kit	Alternative material
10	4168.034.117		CONVERTER	1				25,640		

# Plant

Page 1 from 1

Material number: 4657.026.105

Plant: 465710203000

Material-assembly-group-no: 4657.102.030

6 WG 190 (Current date: 23.11.2012) /

INPUT

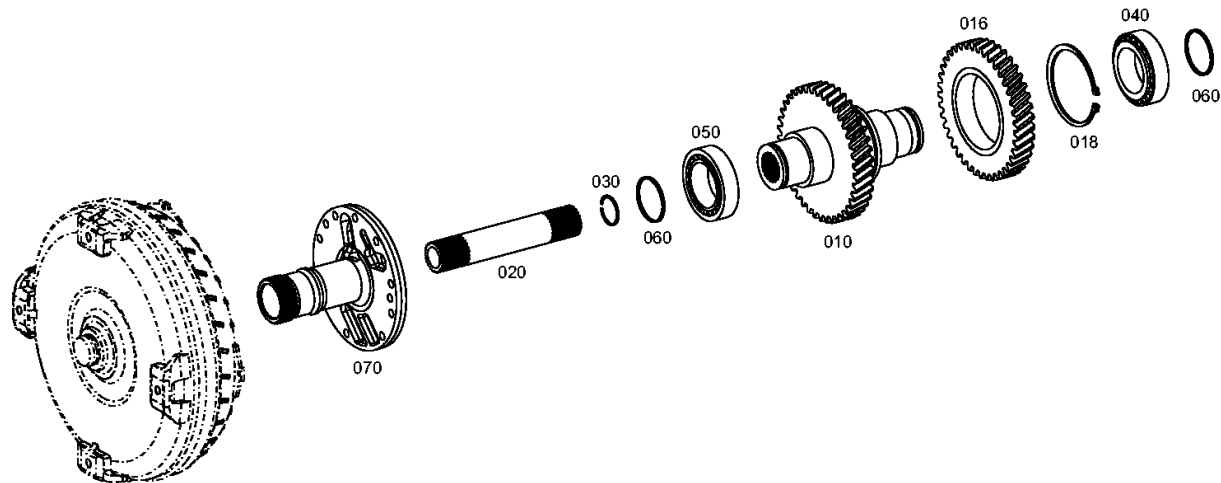

# Parts list

Page 1 from 1

Material number: 4657.026.105

6 WG 190 (Current date: 23.11.2012) /

Plant: 465710203000

Material-assembly-group-no: 4657.102.030



Pos.	Material number	Customer material	Name	Quantity	ME	Amend. no.	Techn. Info.	Weight	Rep kit	Alternative material
10	4657.302.005	140500072	INPUT SHAFT	1			Z=54	8,520		
16	4657.302.004	AT259328	INPUT GEAR	1			Z=53	3,299		
18	0630.501.056	SA 8320-01760	RETAINING RING	1			100X3	0,050		
20	4656.302.010	SA 8320-18800	TURBINE SHAFT	1				1,100		
30	0630.513.099	SA 8320-01890	SNAP RING	1				2,500		
40	0750.117.905	T171126	TAROLLBEARING	1		Z00009825310	60,000X95,000X27,000	0,684		
50	0750.117.905	T171126	TAROLLBEARING	1		Z00009825310	60,000X95,000X27,000	0,684		
60	0634.402.557		R-RING	2			60X3	10		
70	4656.302.036	9305015	STATOR SHAFT	1			Z=46	3,185		

# Plant

Page 1 from 2

Material number: 4657.026.105

Plant: 465710106201

Material-assembly-group-no: 4657.101.062

6 WG 190 (Current date: 23.11.2012) /

GEARBOX HOUSING

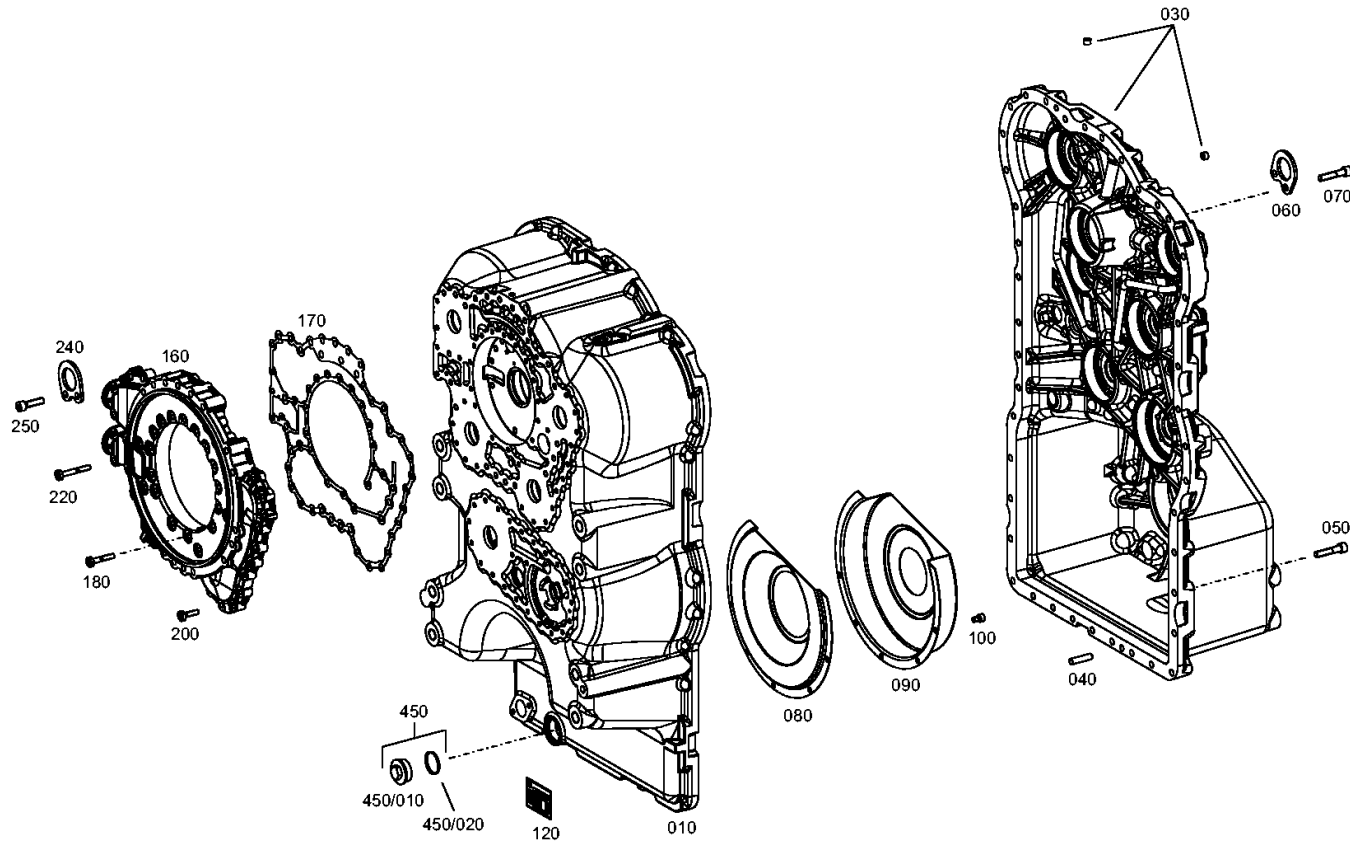



# Plant

Page 2 from 2

Material number: 4657.026.105

Plant: 465710106202

Material-assembly-group-no: 4657.101.062

6 WG 190 (Current date: 23.11.2012) /

GEARBOX HOUSING

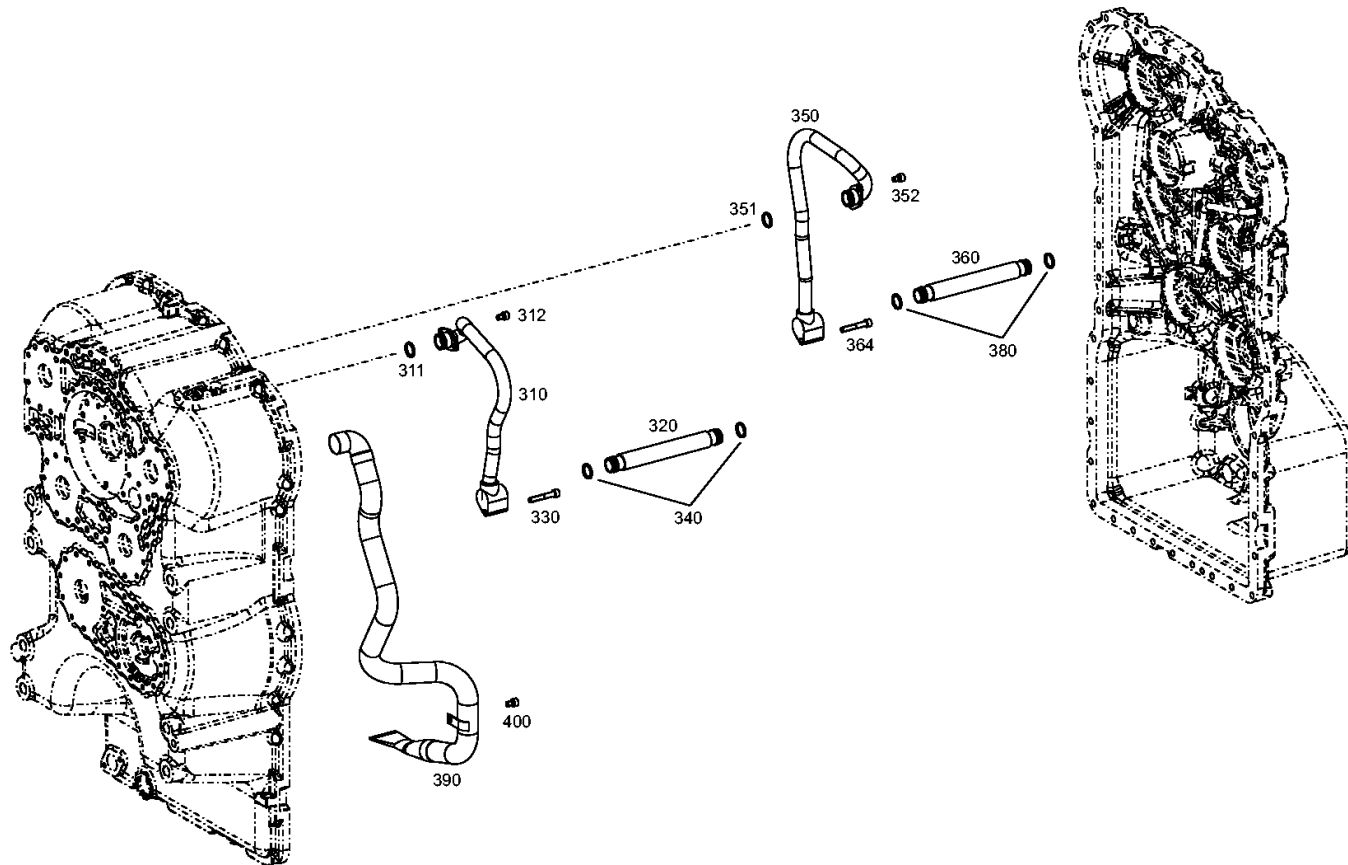

# Parts list

Page 1 from 3

Material number: 4657.026.105

6 WG 190 (Current date: 23.11.2012) /

Plant: 465710106201

Material-assembly-group-no: 4657.101.062



Pos.	Material number	Customer material	Name	Quantity	ME	Amend. no.	Techn. Info.	Weight	Rep kit	Alternative material
10	4657.201.099	T242442	HOUSFRONT SECT	1				93,700		
30	4472.239.198	84357351	HOUSREAR SECT	1				79,250		
30	4657.201.112	110931-00755	HOUSREAR SECT					79,250		4472..23.9.1
40	0631.306.816	VOE15077503	CYLINDRICAL PIN	2			10X24	15		
50	0636.101.115	SA 8320-03200	CAP SCREW	40			M10X50	38		
60	4656.301.018	SA 8320-18770	FIXING PLATE	1				90		
70	0636.101.115	SA 8320-03200	CAP SCREW	2			M10X50	38		
80	4657.301.032	76081015	SCREEN SHEET	1				0,522		
90	4657.301.033	T173812	SCREEN SHEET	1				710		
100	0636.101.644	SA 8320-03800	CAP SCREW	5			M8X12	10		
120	0730.365.092		TYPE PLATE	1			ZF-Standard/Passau	0,010		
160	4656.301.047	K9004016	OIL FEEDHOUSG	1				4,359		
170	4656.301.023	9301468	GASKET	1				15		
180	0736.101.334	SA 8320-07790	TORX SCREW	21			M8X45	22,700		
200	0736.101.312	SA 8320-07780	TORX SCREW	15			M8X30	18		
220	0736.101.335	SA 8320-07800	TORX SCREW	4			M8X60	27,200		

# Parts list

Page 2 from 3

Material number: 4657.026.105

6 WG 190 (Current date: 23.11.2012) /

Plant: 465710106201

Material-assembly-group-no: 4657.101.062



Pos.	Material number	Customer material	Name	Quantity	ME	Amend. no.	Techn. Info.	Weight	Rep kit	Alternative material
240	4656.301.018	SA 8320-18770	FIXING PLATE	1				90		
250	0636.101.708	SA 8320-27440	CAP SCREW	2			M10X40	32		
310	0501.213.219	T197462	OIL TUBE	1				645		
311	0634.306.213	1000000285	O-RING	1			22X3	0,001		
312	0636.101.644	SA 8320-03800	CAP SCREW	2			M8X12	10		
320	4657.301.044	T174389	OIL TUBE	1				480		
330	0636.101.663	0636 101 663	CAP SCREW	1			M8X50	22,700		
340	0634.306.213	1000000285	O-RING	2			22X3	0,001		
350	0501.213.220	T197463	OIL TUBE	1				725		
351	0634.306.213	1000000285	O-RING	1			22X3	0,001		
352	0636.101.644	SA 8320-03800	CAP SCREW	2			M8X12	10		
360	4657.301.044	T174389	OIL TUBE	1				480		
364	0636.101.663	0636 101 663	CAP SCREW	1			M8X50	22,700		
380	0634.306.213	1000000285	O-RING	2			22X3	0,001		
390	0501.218.764	420406-00812	SUCTION TUBE	1				0,925		
400	0636.101.644	SA 8320-03800	CAP SCREW	1			M8X12	10		

# Parts list

Page 3 from 3

Material number: 4657.026.105

6 WG 190 (Current date: 23.11.2012) /

Plant: 465710106201

Material-assembly-group-no: 4657.101.062



Pos.	Material number	Customer material	Name	Quantity	ME	Amend. no.	Techn. Info.	Weight	Rep kit	Alternative material
450	---	8603319	SCREW PLUG	1			CM38X1,5 MIT O-RING	140		
/20	0634.314. 304	9301477	O-RING	1			35X2	1		

# Plant

Page 1 from 1

Material number: 4657.026.105

Plant: 465710140800

Material-assembly-group-no: 4657.101.408

6 WG 190 (Current date: 23.11.2012) /

GEARBOX HOUSING

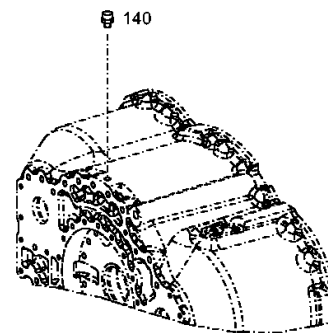

# Parts list

Page 1 from 1

Material number: 4657.026.105

6 WG 190 (Current date: 23.11.2012) /

Plant: 465710140800

Material-assembly-group-no: 4657.101.408



Pos.	Material number	Customer material	Name	Quantity	ME	Amend. no.	Techn. Info.	Weight	Rep kit	Alternative material
140	0750.131.027	50359078	BREATHER	1				10		

# Plant

Page 1 from 1

Material number: 4657.026.105

Plant: 465717103000

Material-assembly-group-no: 4657.171.030

6 WG 190 (Current date: 23.11.2012) /

COUPLING

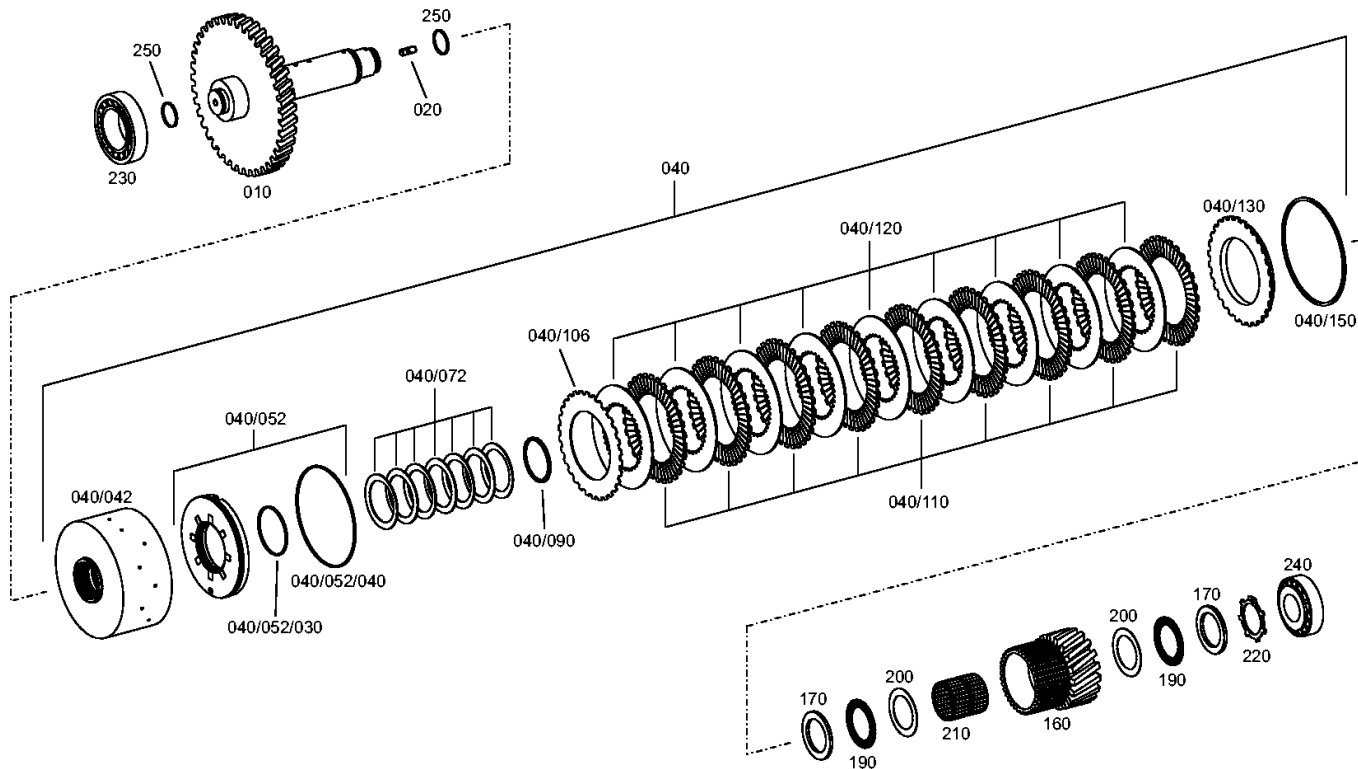

# Parts list

Page 1 from 3

Material number: 4657.026.105

6 WG 190 (Current date: 23.11.2012) /

Plant: 465717103000

Material-assembly-group-no: 4657.171.030



Pos.	Material number	Customer material	Name	Quantity	ME	Amend. no.	Techn. Info.	Weight	Rep kit	Alternative material
10	4657.371.039		SHAFT	1		Z00009825310	Z=57 D-Teil	16,090		
20	0636.607.039	SA 8320-04030	STUD	1			M10X16	13		
40	4657.271.009	87757163	COUPLING	1			KPL.	7,350		
/42	4657.371.034	T242450	DISC CARRIER	1			Z=34	5,800		
/52	4657.271.008	T242451	PISTON	1			KPL. KR/KV/K2/K3/K4	0,400		
//30	0634.313.643	SA 8320-02530	O-RING	1			75X3	10		
//40	0634.313.796	SA 8320-02590	O-RING	1			158X3	7		
/72	0501.316.541	1.131-00120	CUP SPRING	7				33		
/90	0501.324.228	84141985	L-RING	1				200		
/106	0501.212.371	SA 8320-00850	FRICITION DISC	1				0,130		
/110	0501.212.370		DISC	9				0,135		
/120	0501.316.592	SA 8320-01310	ICLUTCH DISC	9				260		
/130	0750.101.182		END SHIM	1			177,4X11,2	0,915		
/150	---		SNAP RING	1				0,000		
---	0730.513.701	AT259447	SNAP RING	1			h=2,1	0,035		
---	0730.513.702	1.115-00320	SNAP RING	1			h=2,25	0,040		



# Parts list

Page 2 from 3

Material number: 4657.026.105

Plant: 465717103000

Material-assembly-group-no: 4657.171.030

6 WG 190 (Current date: 23.11.2012) /



Pos.	Material number	Customer material	Name	Quantity	ME	Amend. no.	Techn. Info.	Weight	Rep kit	Alternative material
---	0730.513.703	1.115-00322	SNAP RING	1			h=2,4	0,040		
---	0730.513.704	AT259450	SNAP RING	1			h=2,55	0,040		
---	0730.513.705	SA 8320-07040	SNAP RING	1			h=2,7	0,043		
---	0730.513.706	AT259452	SNAP RING	1			h=2,85	0,045		
---	0730.513.707	SA 8320-07060	SNAP RING	1			h=3,0	0,048		
---	0730.513.708	8603495	SNAP RING	1			h=3,15	0,048		
---	0730.513.709	1.115-00334	SNAP RING	1			h=3,30	0,053		
---	0730.513.710	AT259456	SNAP RING	1			h=3,45	0,048		
---	0730.513.711	SA 8320-07100	SNAP RING	1			h=3,60	0,048		
---	0730.513.712	1.115-00340	SNAP RING	1			h=3,75	0,062		
---	0730.513.713	1.115-00342	SNAP RING	1			h=3,90	0,063		
---	0730.513.714	1.115-00344	SNAP RING	1			h=4,05	0,066		
---	0730.513.715	SA 8320-07140	SNAP RING	1			h=4,20	0,070		
160	4657.371.022		IDLER	1			Z=20	3,615		
170	0635.290.114	SA 8320-02820	RUNNING DISK	2			55X78X5	90		
190	0735.368.076	SA 8320-07640	AXIAL NEEDLE CAGE	2			55,0X78,0X3,0	25		

# Parts list

Page 3 from 3

Material number: 4657.026.105

6 WG 190 (Current date: 23.11.2012) /

Plant: 465717103000

Material-assembly-group-no: 4657.171.030



Pos.	Material number	Customer material	Name	Quantity	ME	Amend. no.	Techn. Info.	Weight	Rep kit	Alternative material
200	0635.290.012	SA 8320-02810	AXIAL WASHER	2			55X78X1	18		
210	0735.321.509	SA 8320-07580	NEEDLE CAGE	1			K 55,0X63,0X64,0	0,256		
220	0501.316.378	SA 8320-01220	RETAINING RING	1				0,030		
230	0750.117.903		TAROLLBEARING	1		Z00009825310	66,675X112,712X30,162	1,161		
240	0750.117.904		TAROLLBEARING	1		Z00009825310	44,450X95,250X27,783	0,954		
250	0734.401.267	9300413	PISTON RING	2				0,003		

# Plant

Page 1 from 1

Material number: 4657.026.105

Plant: 465717202700

Material-assembly-group-no: 4657.172.027

6 WG 190 (Current date: 23.11.2012) /

COUPLING

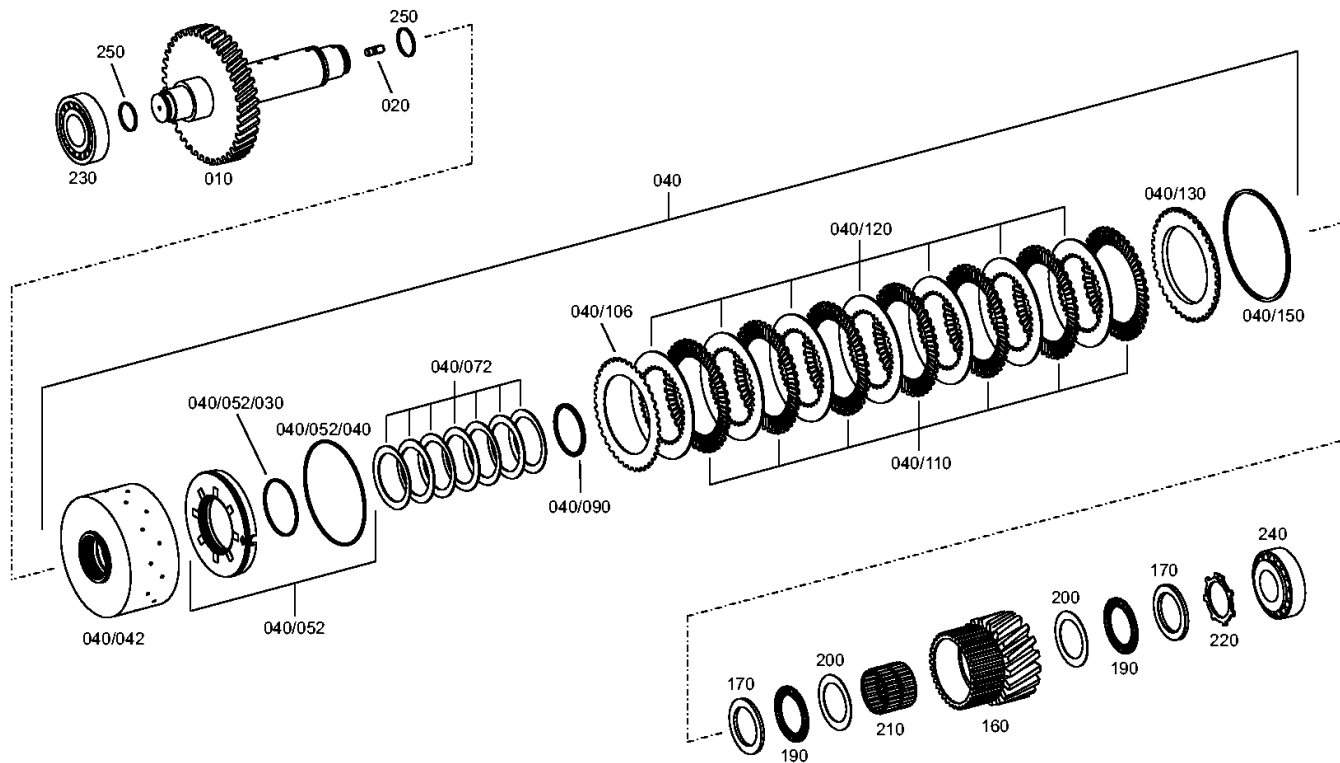

# Parts list

Page 1 from 3

Material number: 4657.026.105

6 WG 190 (Current date: 23.11.2012) /

Plant: 465717202700

Material-assembly-group-no: 4657.172.027



Pos.	Material number	Customer material	Name	Quantity	ME	Amend. no.	Techn. Info.	Weight	Rep kit	Alternative material
10	4657.372.022	130712-00820	SHAFT	1		Z00010882110	D-Teil Z=56	10,530		
20	0636.607.039	SA 8320-04030	STUD	1			M10X16	13		
40	4657.272.005	87757164	COUPLING	1			KPL.	7,350		
/42	4657.372.020	T242453	DISC CARRIER	1			Z=44	4,600		
/52	4657.275.006	4657275006	PISTON	1			KPL.	0,430		
//30	0634.313.643	SA 8320-02530	O-RING	1			75X3	10		
//40	0634.313.719	1.180-00089	O-RING	1			142X3	6		
/72	0501.316.541	1.131-00120	CUP SPRING	7				33		
/90	0501.324.228	84141985	L-RING	1				200		
/106	0501.212.373	KD41416001	OCLUTCH DISC	1				0,085		
/110	0501.212.372	KD41416002	DISC	7			h=2.5	0,090		
/120	0501.316.591	550/42966	ICLUTCH DISC	7				175		
/130	0750.101.183	84395182	END SHIM	1			159,0X8	0,425		
/150	---		SNAP RING	1				0,000		
---	0730.513.684	SA 8320-06850	SNAP RING	1			h=2,10	30		
---	0730.513.685	SA 8320-06860	SNAP RING	1			h=2,25	40		

# Parts list

Page 2 from 3

Material number: 4657.026.105

6 WG 190 (Current date: 23.11.2012) /

Plant: 465717202700

Material-assembly-group-no: 4657.172.027



Pos.	Material number	Customer material	Name	Quantity	ME	Amend. no.	Techn. Info.	Weight	Rep kit	Alternative material
---	0730.513.686	SA 8320-06870	SNAP RING	1			h=2,40	35		
---	0730.513.687	SA 8320-06880	SNAP RING	1			h=2,55	40		
---	0730.513.688	SA 8320-06890	SNAP RING	1			h=2,70	40		
---	0730.513.698	SA 8320-06990	SNAP RING	1			h=2.85	40		
---	0730.513.689	SA 8320-06900	SNAP RING	1			h=3,00	43		
---	0730.513.690	SA 8320-06910	SNAP RING	1			h=3,15	45		
---	0730.513.691	550/42934	SNAP RING	1			h=3,30	48		
---	0730.513.692	SA 8320-06930	SNAP RING	1			h=3,45	50		
---	0730.513.693	SA 8320-06940	SNAP RING	1			h=3,60	43		
---	0730.513.694	SA 8320-06950	SNAP RING	1			h=3,75	55		
---	0730.513.695	SA 8320-06960	SNAP RING	1			h=3,90	55		
---	0730.513.696	1.115-00345	SNAP RING	1			h=4,05	0,059		
---	0730.513.697	T172251	SNAP RING	1			h=4,20	61		
160	4657.372.012		IDLER	1			Z=20	3,227		
170	0635.290.114	SA 8320-02820	RUNNING DISK	2			55X78X5	90		
190	0735.368.076	SA 8320-07640	AXIAL NEEDLE CAGE	2			55,0X78,0X3,0	25		

# Parts list

Page 3 from 3

Material number: 4657.026.105

6 WG 190 (Current date: 23.11.2012) /

Plant: 465717202700

Material-assembly-group-no: 4657.172.027



Pos.	Material number	Customer material	Name	Quantity	ME	Amend. no.	Techn. Info.	Weight	Rep kit	Alternative material
200	0635.290.012	SA 8320-02810	AXIAL WASHER	2			55X78X1	18		
210	0735.321.508	8603643	NEEDLE CAGE	1			K 55,0X63,0X50,0	0,200		
220	0501.316.378	SA 8320-01220	RETAINING RING	1				0,030		
230	0750.117.904		TAROLLBEARING	1		Z00009825310	44,450X95,250X27,783	0,954		
240	0750.117.904		TAROLLBEARING	1		Z00009825310	44,450X95,250X27,783	0,954		
250	0734.401.267	9300413	PISTON RING	2				0,003		

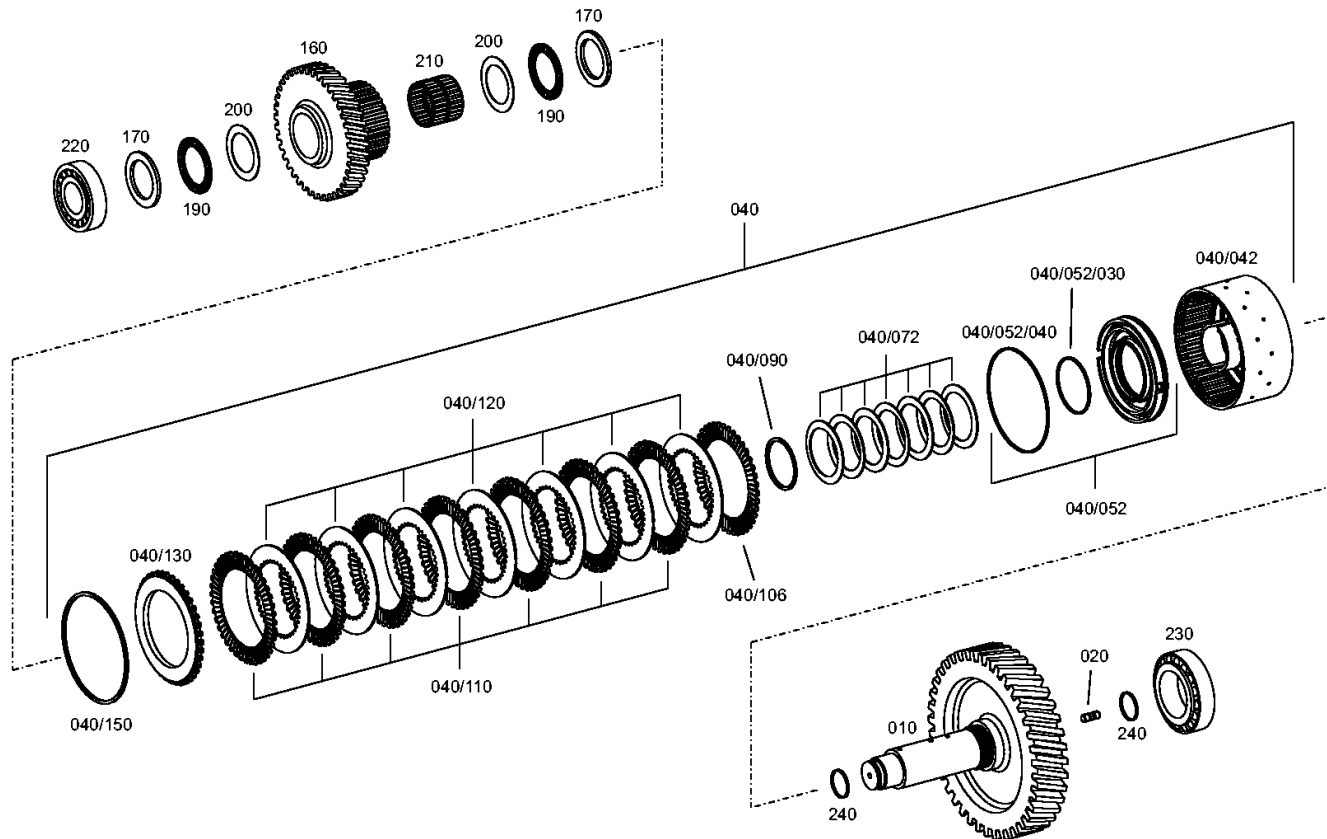

# Parts list

Page 1 from 3

Material number: 4657.026.105

6 WG 190 (Current date: 23.11.2012) /

Plant: 465717302900

Material-assembly-group-no: 4657.173.029



Pos.	Material number	Customer material	Name	Quantity	ME	Amend. no.	Techn. Info.	Weight	Rep kit	Alternative material
10	4657.373.017	84356936	SHAFT	1		Z00009825310	Z=47 D-Teil	16,020		
20	0636.607.039	SA 8320-04030	STUD	1			M10X16	13		
40	4657.273.006	AT357960	COUPLING	1			KPL.	7,350		
/42	4657.372.020	T242453	DISC CARRIER	1			Z=44	4,600		
/52	4657.275.006	4657275006	PISTON	1			KPL.	0,430		
//30	0634.313.643	SA 8320-02530	O-RING	1			75X3	10		
//40	0634.313.719	1.180-00089	O-RING	1			142X3	6		
/72	0501.316.541	1.131-00120	CUP SPRING	7				33		
/90	0501.324.228	84141985	L-RING	1				200		
/106	0501.212.373	KD41416001	OCLUTCH DISC	1				0,085		
/110	0501.212.372	KD41416002	DISC	7			h=2.5	0,090		
/120	0501.316.591	550/42966	ICLUTCH DISC	7				175		
/130	0750.101.183	84395182	END SHIM	1			159,0X8	0,425		
/150	---		SNAP RING	1				0,000		
---	0730.513.684	SA 8320-06850	SNAP RING	1			h=2,10	30		
---	0730.513.685	SA 8320-06860	SNAP RING	1			h=2,25	40		



# Parts list

Page 2 from 3

Material number: 4657.026.105

6 WG 190 (Current date: 23.11.2012) /

Plant: 465717302900

Material-assembly-group-no: 4657.173.029



Pos.	Material number	Customer material	Name	Quantity	ME	Amend. no.	Techn. Info.	Weight	Rep kit	Alternative material
---	0730.513.686	SA 8320-06870	SNAP RING	1			h=2,40	35		
---	0730.513.687	SA 8320-06880	SNAP RING	1			h=2,55	40		
---	0730.513.688	SA 8320-06890	SNAP RING	1			h=2,70	40		
---	0730.513.698	SA 8320-06990	SNAP RING	1			h=2.85	40		
---	0730.513.689	SA 8320-06900	SNAP RING	1			h=3,00	43		
---	0730.513.690	SA 8320-06910	SNAP RING	1			h=3,15	45		
---	0730.513.691	550/42934	SNAP RING	1			h=3,30	48		
---	0730.513.692	SA 8320-06930	SNAP RING	1			h=3,45	50		
---	0730.513.693	SA 8320-06940	SNAP RING	1			h=3,60	43		
---	0730.513.694	SA 8320-06950	SNAP RING	1			h=3,75	55		
---	0730.513.695	SA 8320-06960	SNAP RING	1			h=3,90	55		
---	0730.513.696	1.115-00345	SNAP RING	1			h=4,05	0,059		
---	0730.513.697	T172251	SNAP RING	1			h=4,20	61		
160	4657.373.004	8603512	IDLER	1			Z=55	6,621		
170	0635.290.114	SA 8320-02820	RUNNING DISK	2			55X78X5	90		
190	0735.368.076	SA 8320-07640	AXIAL NEEDLE CAGE	2			55,0X78,0X3,0	25		

## Parts list

Page 3 from 3

Material number: 4657.026.105

6 WG 190 (Current date: 23.11.2012) /

Plant: 465717302900

Material-assembly-group-no: 4657.173.029



Pos.	Material number	Customer material	Name	Quantity	ME	Amend. no.	Techn. Info.	Weight	Rep kit	Alternative material
200	0635.290.012	SA 8320-02810	AXIAL WASHER	2			55X78X1	18		
210	0735.321.508	8603643	NEEDLE CAGE	1			K 55,0X63,0X50,0	0,200		
220	0750.117.904		TAROLLBEARING	1		Z00009825310	44,450X95,250X27,783	0,954		
230	0750.117.903		TAROLLBEARING	1		Z00009825310	66,675X112,712X30,162	1,161		
240	0734.401.267	9300413	PISTON RING	2				0,003		

# Plant

Page 1 from 1

Material number: 4657.026.105

Plant: 465717403800

Material-assembly-group-no: 4657.174.038

6 WG 190 (Current date: 23.11.2012) /

COUPLING

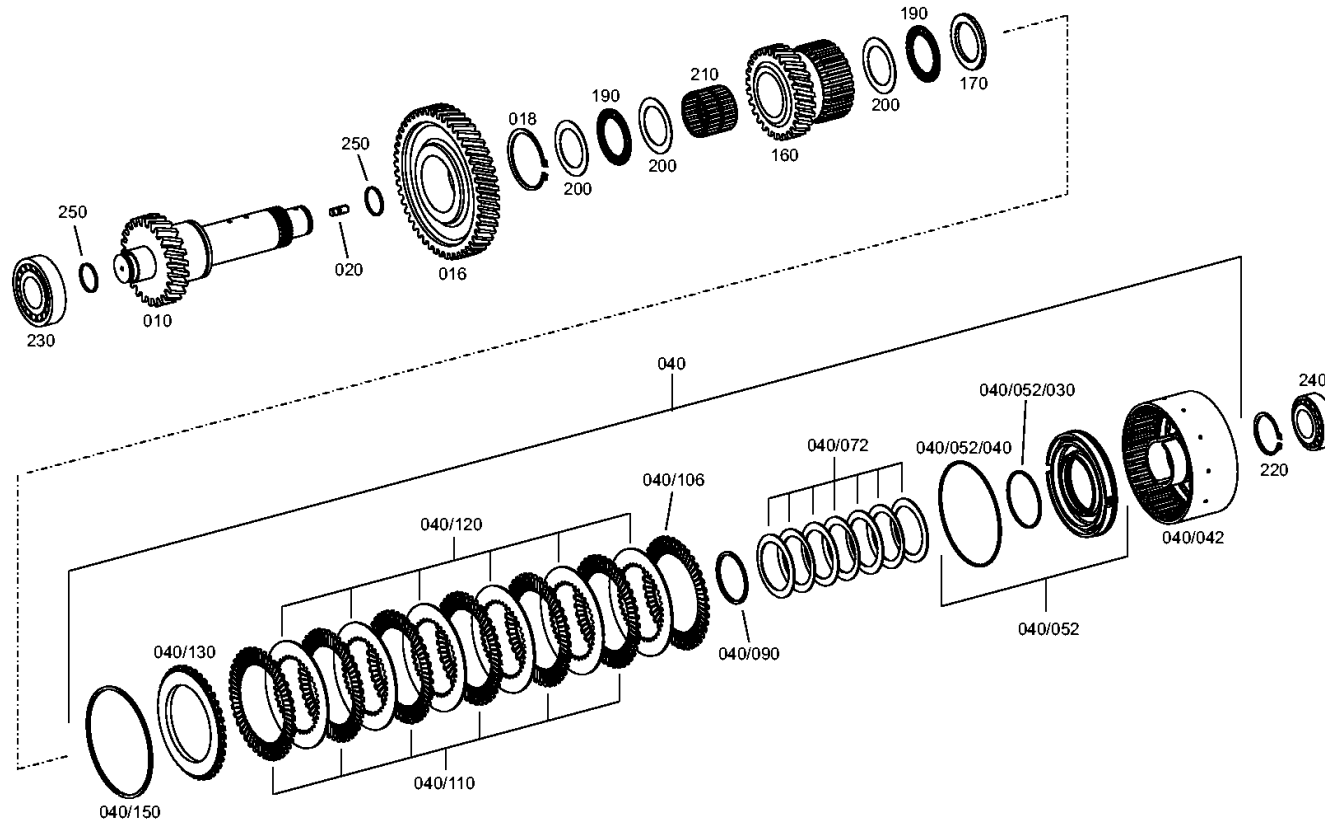

# Parts list

Page 1 from 3

Material number: 4657.026.105

6 WG 190 (Current date: 23.11.2012) /

Plant: 465717403800

Material-assembly-group-no: 4657.174.038



Pos.	Material number	Customer material	Name	Quantity	ME	Amend. no.	Techn. Info.	Weight	Rep kit	Alternative material
10	4657.374.038		SHAFT	1		Z00009825310	Z=26 D-Teil	7,990		
16	4657.374.008	T173859	GEAR	1			Z=63	5,100		
18	0630.501.050	8000450	RETAINING RING	1			80X2,5	27		
20	0636.607.039	SA 8320-04030	STUD	1			M10X16	13		
40	4657.274.016	AT357961	COUPLING	1			KPL.	7,350		
/42	4657.374.037	T245474	DISC CARRIER	1			Z=44	3,600		
/52	4657.275.006	4657275006	PISTON	1			KPL.	0,430		
//30	0634.313.643	SA 8320-02530	O-RING	1			75X3	10		
//40	0634.313.719	1.180-00089	O-RING	1			142X3	6		
/72	0501.316.541	1.131-00120	CUP SPRING	7				33		
/90	0501.324.228	84141985	L-RING	1				200		
/106	0501.212.373	KD41416001	OCLUTCH DISC	1				0,085		
/110	0501.212.372	KD41416002	DISC	6			h=2.5	0,090		
/120	0501.316.591	550/42966	ICLUTCH DISC	6				175		
/130	0750.101.183	84395182	END SHIM	1			159,0X8	0,425		
/150	---		SNAP RING	1				0,000		

# Parts list

Page 2 from 3

Material number: 4657.026.105

Plant: 465717403800

Material-assembly-group-no: 4657.174.038

6 WG 190 (Current date: 23.11.2012) /



Pos.	Material number	Customer material	Name	Quantity	ME	Amend. no.	Techn. Info.	Weight	Rep kit	Alternative material
---	0730.513.684	SA 8320-06850	SNAP RING	1			h=2,10	30		
---	0730.513.685	SA 8320-06860	SNAP RING	1			h=2,25	40		
---	0730.513.686	SA 8320-06870	SNAP RING	1			h=2,40	35		
---	0730.513.687	SA 8320-06880	SNAP RING	1			h=2,55	40		
---	0730.513.688	SA 8320-06890	SNAP RING	1			h=2,70	40		
---	0730.513.698	SA 8320-06990	SNAP RING	1			h=2.85	40		
---	0730.513.689	SA 8320-06900	SNAP RING	1			h=3,00	43		
---	0730.513.690	SA 8320-06910	SNAP RING	1			h=3,15	45		
---	0730.513.691	550/42934	SNAP RING	1			h=3,30	48		
---	0730.513.692	SA 8320-06930	SNAP RING	1			h=3,45	50		
---	0730.513.693	SA 8320-06940	SNAP RING	1			h=3,60	43		
---	0730.513.694	SA 8320-06950	SNAP RING	1			h=3,75	55		
---	0730.513.695	SA 8320-06960	SNAP RING	1			h=3,90	55		
---	0730.513.696	1.115-00345	SNAP RING	1			h=4,05	0,059		
---	0730.513.697	T172251	SNAP RING	1			h=4,20	61		
160	4657.374.011	8900129718	IDLER	1			Z=38	0,010		

# Parts list

Page 3 from 3

Material number: 4657.026.105

6 WG 190 (Current date: 23.11.2012) /

Plant: 465717403800

Material-assembly-group-no: 4657.174.038



Pos.	Material number	Customer material	Name	Quantity	ME	Amend. no.	Techn. Info.	Weight	Rep kit	Alternative material
170	0635.290.114	SA 8320-02820	RUNNING DISK	1			55X78X5	90		
190	0735.368.076	SA 8320-07640	AXIAL NEEDLE CAGE	2			55,0X78,0X3,0	25		
200	0635.290.012	SA 8320-02810	AXIAL WASHER	3			55X78X1	18		
210	0735.321.508	8603643	NEEDLE CAGE	1			K 55,0X63,0X50,0	0,200		
220	0630.501.038	1000000210	RETAINING RING	1			55X2	12		
230	0750.117.904		TAROLLBEARING	1		Z00009825310	44,450X95,250X27,783	0,954		
240	0750.117.906	VOE15078595	TAROLLBEARING	1		Z00009825310	39,688X76,200X23,812	0,479		
250	0734.401.267	9300413	PISTON RING	2				0,003		

# Plant

Page 1 from 1

Material number: 4657.026.105

Plant: 465717501400

Material-assembly-group-no: 4657.175.014

6 WG 190 (Current date: 23.11.2012) /

COUPLING

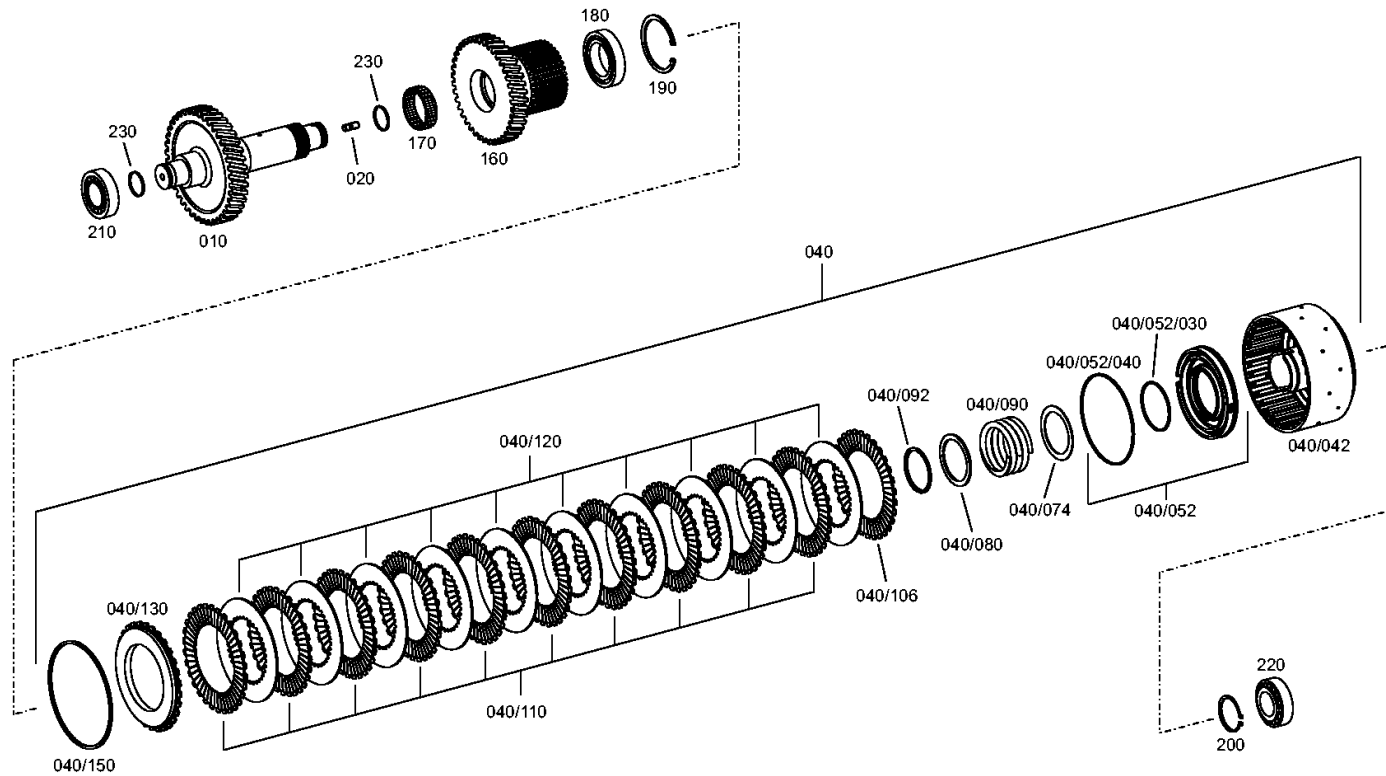

# Parts list

Page 1 from 3

Material number: 4657.026.105

6 WG 190 (Current date: 23.11.2012) /

Plant: 465717501400

Material-assembly-group-no: 4657.175.014



Pos.	Material number	Customer material	Name	Quantity	ME	Amend. no.	Techn. Info.	Weight	Rep kit	Alternative material
10	4657.375.020	130712-00825	SHAFT	1		Z00009825310	Z=55 D-Teil	10,200		
20	0636.607.039	SA 8320-04030	STUD	1			M10X16	13		
40	4657.275.010	AT357962	COUPLING	1			4WG 210 KV/ KR / KPL.	7,350		
/42	4657.375.019	T242455	DISC CARRIER	1			Z=34	5,300		
/52	4657.275.006	4657275006	PISTON	1			KPL.	0,430		
//30	0634.313.643	SA 8320-02530	O-RING	1			75X3	10		
//40	0634.313.719	1.180-00089	O-RING	1			142X3	6		
/74	0730.110.373	SA 8320-06630	WASHER	1				25		
/80	0730.011.028	K9006642	SUPPORT SHIM	1				45		
/90	0732.042.711	SA 8320-07450	COMPRSPRING	1				448		
/92	0501.324.228	84141985	L-RING	1				200		
/106	0501.212.371	SA 8320-00850	FRICITION DISC	1				0,130		
/110	0501.212.370		DISC	10				0,135		
/120	0501.316.592	SA 8320-01310	ICLUTCH DISC	10				260		
/130	0750.101.182		END SHIM	1			177,4X11,2	0,915		
/150	---		SNAP RING	1				0,000		



# Parts list

Page 2 from 3

Material number: 4657.026.105

Plant: 465717501400

Material-assembly-group-no: 4657.175.014

6 WG 190 (Current date: 23.11.2012) /



Pos.	Material number	Customer material	Name	Quantity	ME	Amend. no.	Techn. Info.	Weight	Rep kit	Alternative material
---	0730.513.701	AT259447	SNAP RING	1			h=2,1	0,035		
---	0730.513.702	1.115-00320	SNAP RING	1			h=2,25	0,040		
---	0730.513.703	1.115-00322	SNAP RING	1			h=2,4	0,040		
---	0730.513.704	AT259450	SNAP RING	1			h=2,55	0,040		
---	0730.513.705	SA 8320-07040	SNAP RING	1			h=2,7	0,043		
---	0730.513.706	AT259452	SNAP RING	1			h=2,85	0,045		
---	0730.513.707	SA 8320-07060	SNAP RING	1			h=3,0	0,048		
---	0730.513.708	8603495	SNAP RING	1			h=3,15	0,048		
---	0730.513.709	1.115-00334	SNAP RING	1			h=3,30	0,053		
---	0730.513.710	AT259456	SNAP RING	1			h=3,45	0,048		
---	0730.513.711	SA 8320-07100	SNAP RING	1			h=3,60	0,048		
---	0730.513.712	1.115-00340	SNAP RING	1			h=3,75	0,062		
---	0730.513.713	1.115-00342	SNAP RING	1			h=3,90	0,063		
---	0730.513.714	1.115-00344	SNAP RING	1			h=4,05	0,066		
---	0730.513.715	SA 8320-07140	SNAP RING	1			h=4,20	0,070		
160	4657.375.003	127000010	IDLER	1			Z=52	4,460		

# Parts list

Page 3 from 3

Material number: 4657.026.105

6 WG 190 (Current date: 23.11.2012) /

Plant: 465717501400

Material-assembly-group-no: 4657.175.014



Pos.	Material number	Customer material	Name	Quantity	ME	Amend. no.	Techn. Info.	Weight	Rep kit	Alternative material
170	0735.321.408	VOE11716479	NEEDLE CAGE	1			K 60,0X68,0X20,0	72		
180	0750.116.380	1.109-00010	BALL BEARING	1			55,000X90,000X18,000	373		
190	0630.502.042	1000000216	RETAINING RING	1			90X3	34		
200	0630.501.038	1000000210	RETAINING RING	1			55X2	12		
210	0750.117.906	VOE15078595	TAROLLBEARING	1		Z00009825310	39,688X76,200X23,812	0,479		
220	0750.117.906	VOE15078595	TAROLLBEARING	1		Z00009825310	39,688X76,200X23,812	0,479		
230	0734.401.267	9300413	PISTON RING	2				0,003		

# Plant

Page 1 from 1

Material number: 4657.026.105

Plant: 465717601700

Material-assembly-group-no: 4657.176.017

6 WG 190 (Current date: 23.11.2012) /

COUPLING

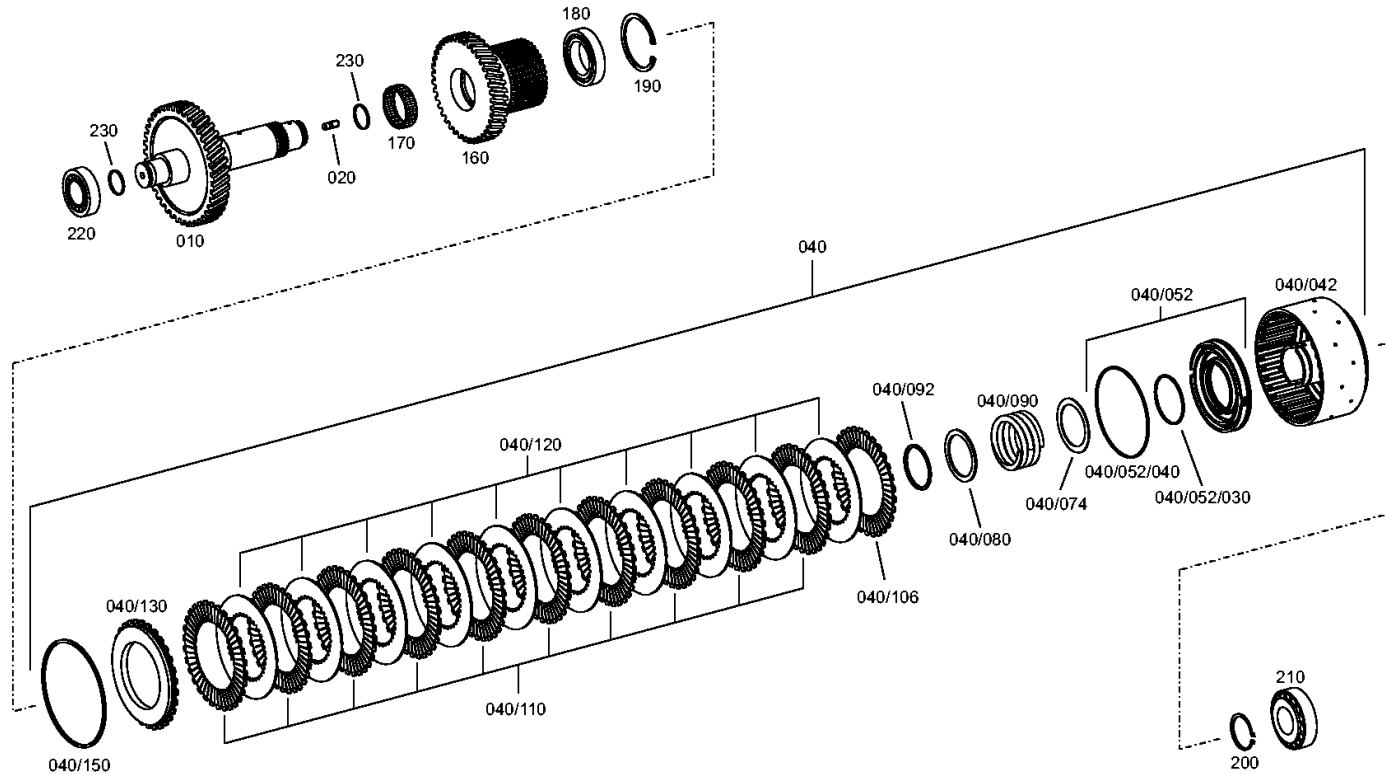

# Parts list

Page 1 from 3

Material number: 4657.026.105

6 WG 190 (Current date: 23.11.2012) /

Plant: 465717601700

Material-assembly-group-no: 4657.176.017



Pos.	Material number	Customer material	Name	Quantity	ME	Amend. no.	Techn. Info.	Weight	Rep kit	Alternative material
10	4657.376.010	130712-00826	SHAFT	1		Z00009825310	Z=58	10,900		
20	0636.607.039	SA 8320-04030	STUD	1			M10X16	13		
40	4657.275.010	AT357962	COUPLING	1			4WG 210 KV/ KR / KPL.	7,350		
/42	4657.375.019	T242455	DISC CARRIER	1			Z=34	5,300		
/52	4657.275.006	4657275006	PISTON	1			KPL.	0,430		
//30	0634.313.643	SA 8320-02530	O-RING	1			75X3	10		
//40	0634.313.719	1.180-00089	O-RING	1			142X3	6		
/74	0730.110.373	SA 8320-06630	WASHER	1				25		
/80	0730.011.028	K9006642	SUPPORT SHIM	1				45		
/90	0732.042.711	SA 8320-07450	COMPRSPRING	1				448		
/92	0501.324.228	84141985	L-RING	1				200		
/106	0501.212.371	SA 8320-00850	FRICITION DISC	1				0,130		
/110	0501.212.370		DISC	10				0,135		
/120	0501.316.592	SA 8320-01310	ICLUTCH DISC	10				260		
/130	0750.101.182		END SHIM	1			177,4X11,2	0,915		
/150	---		SNAP RING	1				0,000		

# Parts list

Page 2 from 3

Material number: 4657.026.105

6 WG 190 (Current date: 23.11.2012) /

Plant: 465717601700

Material-assembly-group-no: 4657.176.017



Pos.	Material number	Customer material	Name	Quantity	ME	Amend. no.	Techn. Info.	Weight	Rep kit	Alternative material
---	0730.513.701	AT259447	SNAP RING	1			h=2,1	0,035		
---	0730.513.702	1.115-00320	SNAP RING	1			h=2,25	0,040		
---	0730.513.703	1.115-00322	SNAP RING	1			h=2,4	0,040		
---	0730.513.704	AT259450	SNAP RING	1			h=2,55	0,040		
---	0730.513.705	SA 8320-07040	SNAP RING	1			h=2,7	0,043		
---	0730.513.706	AT259452	SNAP RING	1			h=2,85	0,045		
---	0730.513.707	SA 8320-07060	SNAP RING	1			h=3,0	0,048		
---	0730.513.708	8603495	SNAP RING	1			h=3,15	0,048		
---	0730.513.709	1.115-00334	SNAP RING	1			h=3,30	0,053		
---	0730.513.710	AT259456	SNAP RING	1			h=3,45	0,048		
---	0730.513.711	SA 8320-07100	SNAP RING	1			h=3,60	0,048		
---	0730.513.712	1.115-00340	SNAP RING	1			h=3,75	0,062		
---	0730.513.713	1.115-00342	SNAP RING	1			h=3,90	0,063		
---	0730.513.714	1.115-00344	SNAP RING	1			h=4,05	0,066		
---	0730.513.715	SA 8320-07140	SNAP RING	1			h=4,20	0,070		
160	4657.375.003	127000010	IDLER	1			Z=52	4,460		

# Parts list

Page 3 from 3

Material number: 4657.026.105

6 WG 190 (Current date: 23.11.2012) /

Plant: 465717601700

Material-assembly-group-no: 4657.176.017



Pos.	Material number	Customer material	Name	Quantity	ME	Amend. no.	Techn. Info.	Weight	Rep kit	Alternative material
170	0735.321.408	VOE11716479	NEEDLE CAGE	1			K 60,0X68,0X20,0	72		
180	0750.116.380	1.109-00010	BALL BEARING	1			55,000X90,000X18,000	373		
190	0630.502.042	1000000216	RETAINING RING	1			90X3	34		
200	0630.501.038	1000000210	RETAINING RING	1			55X2	12		
210	0750.117.904		TAROLLBEARING	1		Z00009825310	44,450X95,250X27,783	0,954		
220	0750.117.906	VOE15078595	TAROLLBEARING	1		Z00009825310	39,688X76,200X23,812	0,479		
230	0734.401.267	9300413	PISTON RING	2				0,003		

# Plant

Page 1 from 1

Material number: 4657.026.105

Plant: 465710301000

Material-assembly-group-no: 4657.103.010

6 WG 190 (Current date: 23.11.2012) /

OUTPUT

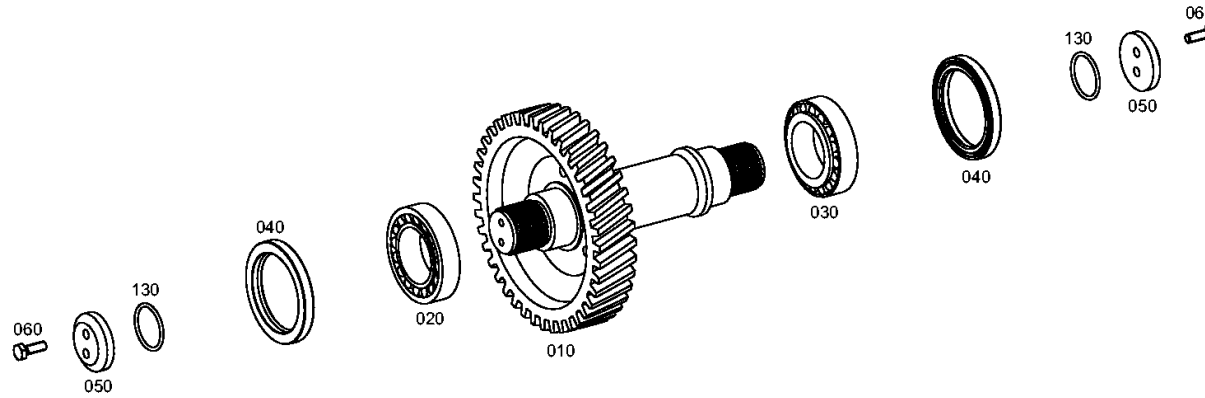

# Parts list

Page 1 from 1

Material number: 4657.026.105

6 WG 190 (Current date: 23.11.2012) /

Plant: 465710301000

Material-assembly-group-no: 4657.103.010



Pos.	Material number	Customer material	Name	Quantity	ME	Amend. no.	Techn. Info.	Weight	Rep kit	Alternative material
10	4657.303.043		OUTPUT SHAFT	1		K01317/0610	Z=46	21,100		
20	0750.117.903		TAROLLBEARING	1		Z0000982531	66,675X112,712X30, 0 162	1,161		
30	0750.117.903		TAROLLBEARING	1		Z0000982531	66,675X112,712X30, 0 162	1,161		
40	0750.111.116	1000000947	SHAFT SEAL	2			90X120X13	0,080		
50	4644.303.259		WASHER	2		K00710/9910		0,373		
60	0636.015.386	SA 8320-03510	HEXAGON BOLT	4			M10X30	3		
130	0634.303.466	9304730	O-RING	2			48X4	2		



# Plant

Page 1 from 1

Material number: 4657.026.105

Plant: 465710342900

Material-assembly-group-no: 4657.103.429

6 WG 190 (Current date: 23.11.2012) /

OUTPUT

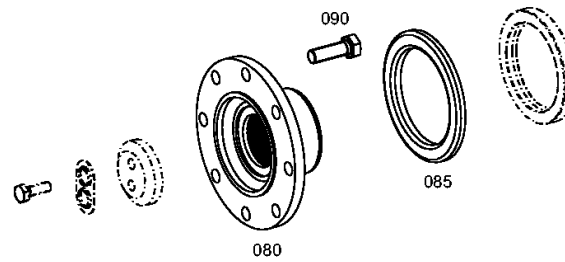

# Parts list

Page 1 from 1

Material number: 4657.026.105

6 WG 190 (Current date: 23.11.2012) /

Plant: 465710342900

Material-assembly-group-no: 4657.103.429



Pos.	Material number	Customer material	Name	Quantity	ME	Amend. no.	Techn. Info.	Weight	Rep kit	Alternative material
80	4657.303.034		OUTPUT FLANGE	1		K01229/0210		3,890		
85	4657.303.018	T180753	SCREEN SHEET	1		K01229/0210		177		
90	0636.020.082		HEXAGON BOLT	8			M14X1,5X45	0,080		

# Plant

Page 1 from 1

Material number: 4657.026.105

Plant: 465710344200

Material-assembly-group-no: 4657.103.442

6 WG 190 (Current date: 23.11.2012) /

OUTPUT

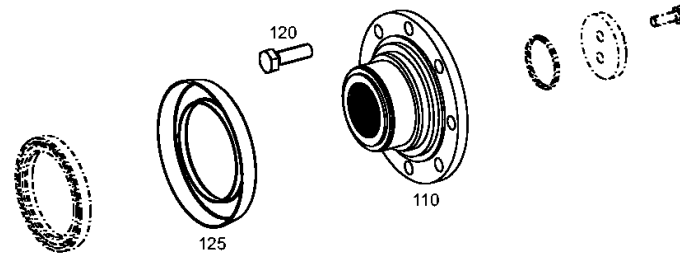

# Parts list

Page 1 from 1

Material number: 4657.026.105

6 WG 190 (Current date: 23.11.2012) /

Plant: 465710344200

Material-assembly-group-no: 4657.103.442



Pos.	Material number	Customer material	Name	Quantity	ME	Amend. no.	Techn. Info.	Weight	Rep kit	Alternative material
110	4657.303.034		OUTPUT FLANGE	1				3,890		
120	0636.020.082		HEXAGON BOLT	8			M14X1,5X45	0,080		
125	4657.303.048	T242439	SCREEN SHEET	1				0,315		

# Plant

Page 1 from 1

Material number: 4657.026.105

Plant: 465715400400

Material-assembly-group-no: 4657.154.004

6 WG 190 (Current date: 23.11.2012) /

POWER TAKE-OFF

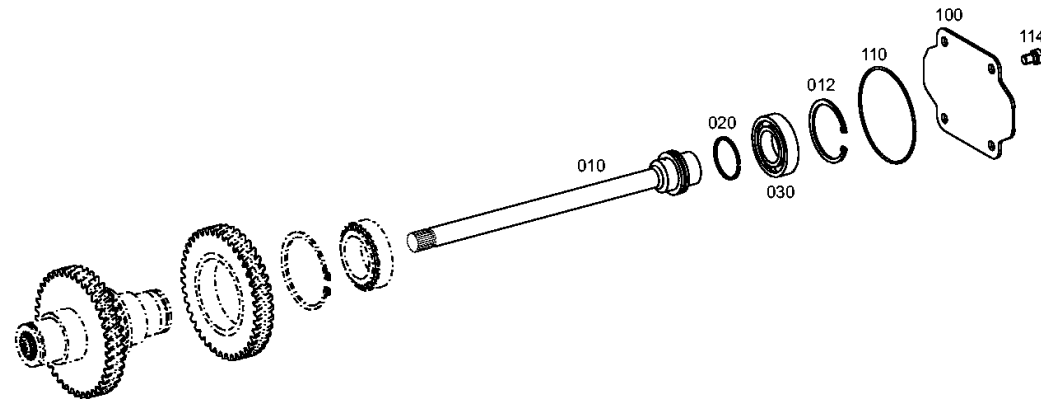

# Parts list

Page 1 from 1

Material number: 4657.026.105

6 WG 190 (Current date: 23.11.2012) /

Plant: 465715400400

Material-assembly-group-no: 4657.154.004



Pos.	Material number	Customer material	Name	Quantity	ME	Amend. no.	Techn. Info.	Weight	Rep kit	Alternative material
10	4657.354.020	9304790	PUMP SHAFT	1		K01714/9710	Z=21	2,300		
12	0630.502.040		RETAINING RING	1			85X3	0,080		
20	0634.402.557		R-RING	1		K01706/0010	60X3	10		
30	0750.116.008	9300455	BALL BEARING	1			45,000X85,000X19,000	0,404		
100	4656.354.009	141200006	COVER PLATE	1		K00889/9710		855		
110	0634.304.616		O-RING	1			130X3	2		
114	0636.016.221	SA 8320-03570	HEXAGON BOLT	4		K00889/9710	M12X18	30		

# Plant

Page 1 from 1

Material number: 4657.026.105

Plant: 465710601200

Material-assembly-group-no: 4657.106.012

6 WG 190 (Current date: 23.11.2012) /

GEAR SHIFT SYSTEM

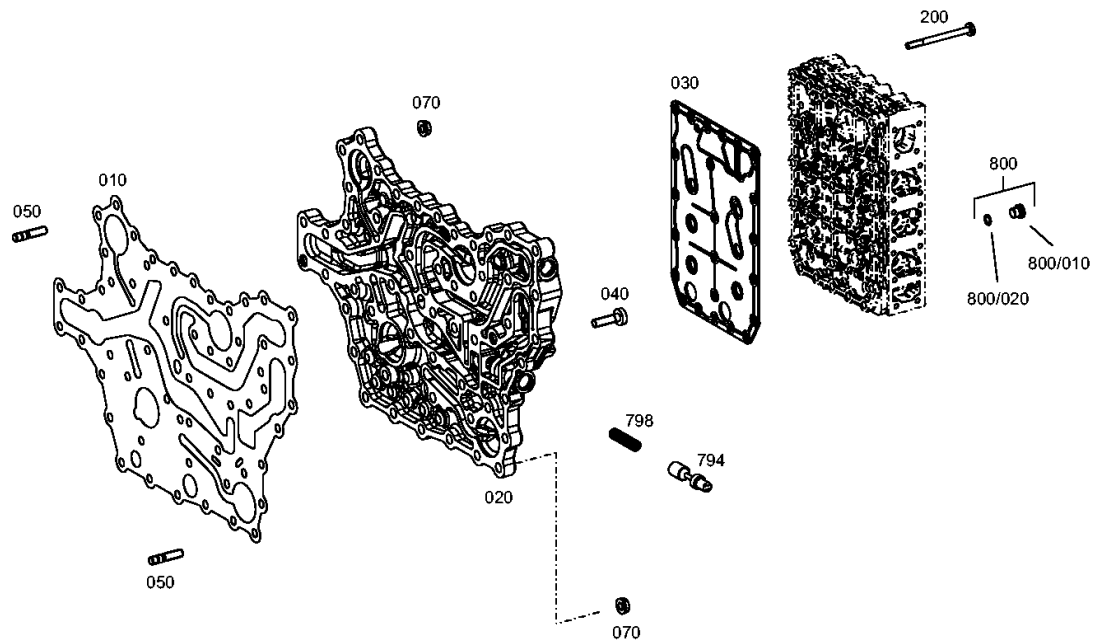

# Parts list

Page 1 from 1

Material number: 4657.026.105

6 WG 190 (Current date: 23.11.2012) /

Plant: 465710601200

Material-assembly-group-no: 4657.106.012



Pos.	Material number	Customer material	Name	Quantity	ME	Amend. no.	Techn. Info.	Weight	Rep kit	Alternative material
10	4657.306.022	1.180-00022	GASKET	1				0,027		
20	4657.306.029	T180481	DUCT PLATE	1				2,960		
30	4656.306.179		INTERMEDIATE SHEET	1		Z00016403510		0,260		
40	0736.101.312	SA 8320-07780	TORX SCREW	36			M8X30	18		
50	0636.607.054	8900128373	STUD	14			M8X25	10		
70	0637.025.005	SA 8320-04140	HEXAGON NUT	14			M8	7		
200	0736.101.408	VOE14527063	TORX SCREW	23			M6X76	20		
794	4657.306.031	K9000609	PISTON	1				15		
798	0732.042.761	T177979	COMPRSPRING	1			D=1,6	9,200		
800	---		SCREW PLUG	8		K01394/0610	M10X1 KPL.MIT O-RING	5		
/20	0634.303.280	1000000265	O-RING	1			8X1,5	0,007		



# Plant

Page 1 from 1

Material number: 4657.026.105

Plant: 465710640720

Material-assembly-group-no: 4657.106.407

6 WG 190 (Current date: 23.11.2012) /

GEAR SHIFT SYSTEM

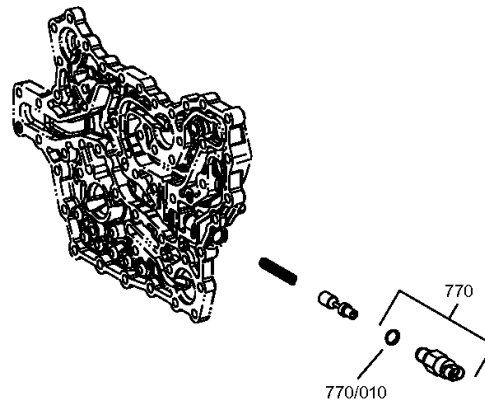

# Parts list

Page 1 from 1

Material number: 4657.026.105

6 WG 190 (Current date: 23.11.2012) /

Plant: 465710640720

Material-assembly-group-no: 4657.106.407



Pos.	Material number	Customer material	Name	Quantity	ME	Amend. no.	Techn. Info.	Weight	Rep kit	Alternative material
770	0501.210. 966	9300030	TAPPET SWITCH	1				75		
/10	0634.306. 523	1000000291	O-RING	1			13X2	0,200		

# Plant

Page 1 from 2

Material number: 4657.026.105

Plant: 465615901921

Material-assembly-group-no: 4656.159.019

6 WG 190 (Current date: 23.11.2012) /

GEAR SHIFT SYSTEM

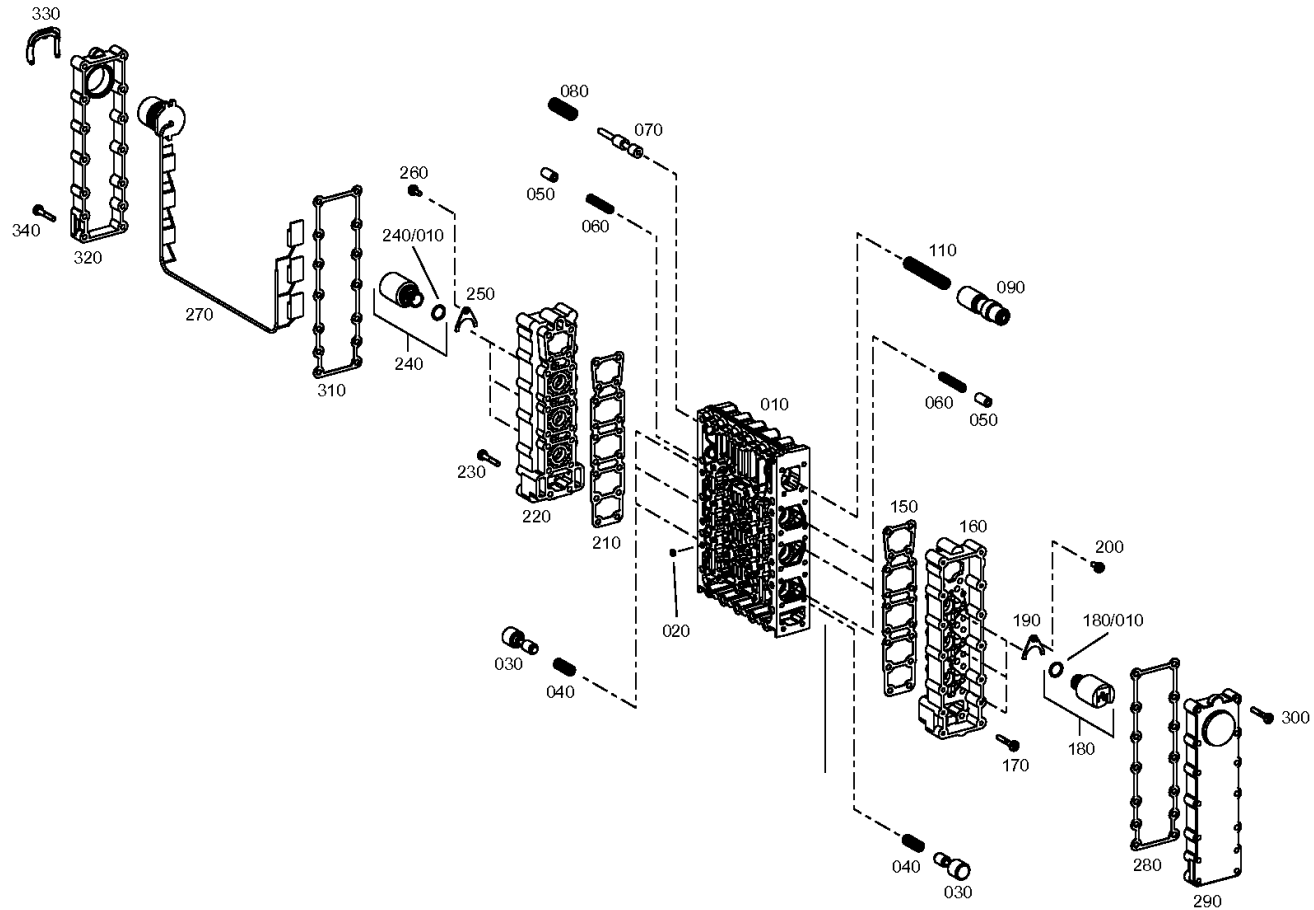

# Plant

Page 2 from 2

Material number: 4657.026.105

Plant: 465615901922

Material-assembly-group-no: 4656.159.019

6 WG 190 (Current date: 23.11.2012) /

GEAR SHIFT SYSTEM

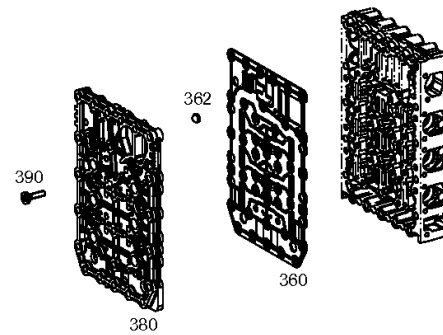

# Parts list

Page 1 from 3

Material number: 4657.026.105

6 WG 190 (Current date: 23.11.2012) /

Plant: 465615901921

Material-assembly-group-no: 4656.159.019



Pos.	Material number	Customer material	Name	Quantity	ME	Amend. no.	Techn. Info.	Weight	Rep kit	Alternative material
10	4656.306.170	K9006652	VALVE BLOCK	1				2,085		
20	0730.361.070	VOE11991257	ORIFICE	6			D=0,8 IN 0730 361 120(2)	0,001		
30	4656.306.095	T173511	PISTON	6				20		
40	0732.042.538	SA 8320-07410	COMPRSPRING	6				5		
50	4656.306.013	SA 8320-18820	PISTON	6				5		
60	0732.042.539	SA 8320-07420	COMPRSPRING	6				0,007		
70	4656.306.074	T173125	PISTON	1				15		
80	0732.042.631	SA 8320-07430	COMPRSPRING	1				15		
90	4656.306.152	K9000101	CONTROL PISTON	1				35		
110	0732.042.719	SA 8320-07460	COMPRSPRING	1				33		
150	4656.306.158	RM 14516389	GASKET	1				5		
160	4656.306.116	VOE14516390	HOUSING	1				0,550		
170	0736.101.257	T173131	TORX SCREW	18			M5	5,700		
180	0501.314.770	SA 8320-01170	PRESSURE REGULATOR	3				0,122		
110	0734.313.134	9300046	ROUND SEALING RING	1				0,001		
190	1043.326.045	ZM 2287667	FIXING PLATE	3				0,003		

# Parts list

Page 2 from 3

Material number: 4657.026.105

6 WG 190 (Current date: 23.11.2012) /

Plant: 465615901921

Material-assembly-group-no: 4656.159.019



Pos.	Material number	Customer material	Name	Quantity	ME	Amend. no.	Techn. Info.	Weight	Rep kit	Alternative material
200	0736.101.094	SA 8320-07720	TORX SCREW	3			M5X12 IN 0736 101 053(2)	3		
210	4656.306.158	RM 14516389	GASKET	1				5		
220	4656.306.116	VOE14516390	HOUSING	1				0,550		
230	0736.101.257	T173131	TORX SCREW	18			M5	5,700		
240	0501.314.770	SA 8320-01170	PRESSURE REGULATOR	3				0,122		
/10	0734.313.134	9300046	ROUND SEALING RING	1				0,001		
250	1043.326.045	ZM 2287667	FIXING PLATE	3				0,003		
260	0736.101.094	SA 8320-07720	TORX SCREW	3			M5X12 IN 0736 101 053(2)	3		
270	4656.206.006	SA 8320-18760	WIRING HARNESS	1				100		
280	4656.306.157	9303083	GASKET	1				5		
290	4656.306.054	T173138	COVER	1				0,270		
300	0736.101.257	T173131	TORX SCREW	14			M5	5,700		
310	4656.306.157	9303083	GASKET	1				5		
320	4656.306.055	143000003	COVER	1				0,530		
330	1058.327.026	SA 8330-00360	RETAINING CLAMP	1				0,020		
340	0736.101.257	T173131	TORX SCREW	14			M5	5,700		

## Parts list

Page 3 from 3

Material number: 4657.026.105

6 WG 190 (Current date: 23.11.2012) /

Plant: 465615901921

Material-assembly-group-no: 4656.159.019



Pos.	Material number	Customer material	Name	Quantity	ME	Amend. no.	Techn. Info.	Weight	Rep kit	Alternative material
360	4656.306.180	8603181	INTERMEDIATE SHEET	1		Z00016403510	D-Teil	0,280		
362	0501.316.715	9300054	SCREEN	6				1		
380	4656.306.150	VOE14527061	DUCT PLATE	1				0,660		
390	0736.101.407	VOE14527062	TORX SCREW	18			M6X23	5		

# Plant

Page 1 from 1

Material number: 4657.026.105

Plant: 465712300300

Material-assembly-group-no: 4657.123.003

6 WG 190 (Current date: 23.11.2012) /

CONTROL UNIT

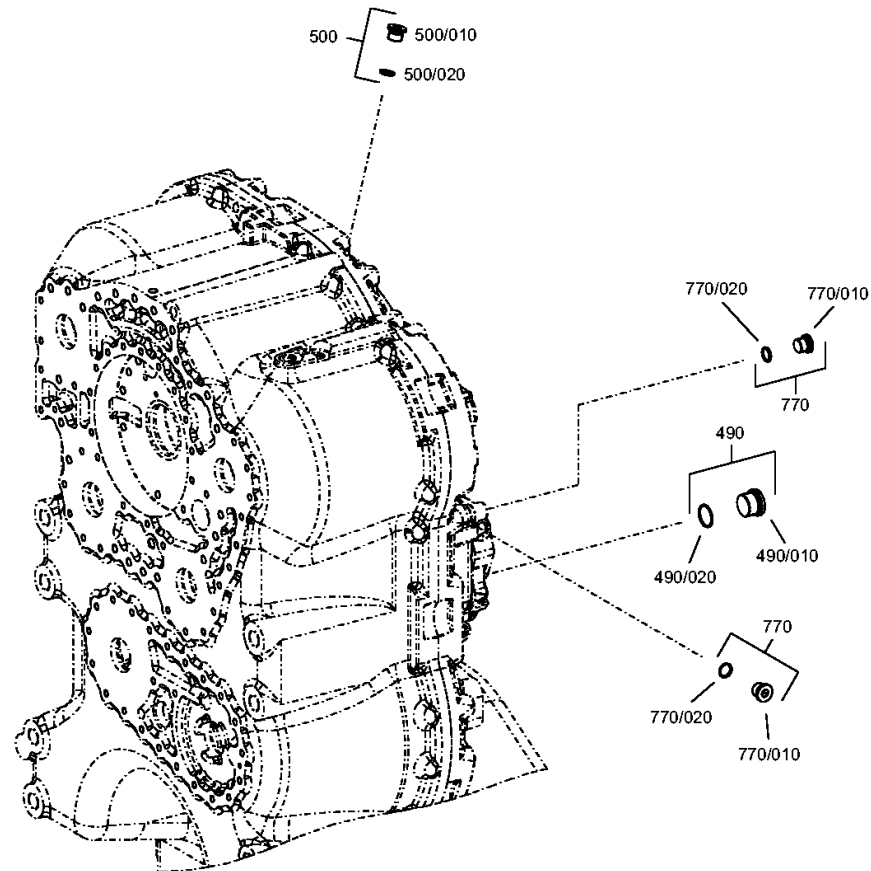



# Parts list

Page 1 from 1

Material number: 4657.026.105

6 WG 190 (Current date: 23.11.2012) /

Plant: 465712300300

Material-assembly-group-no: 4657.123.003



Pos.	Material number	Customer material	Name	Quantity	ME	Amend. no.	Techn. Info.	Weight	Rep kit	Alternative material
490	---	430221-00014	SCREW PLUG	1				75		
/20	0634.313.233	9301962	O-RING	1			23X2	0,005		
500	---	430221-00015	SCREW PLUG	1				20		
/20	0634.316.523	9301941	O-RING	1			13X2	0,004		
770	---	430221-00015	SCREW PLUG	2		K04951/0710		20		
/20	0634.316.523	9301941	O-RING	1			13X2	0,004		

# Plant

Page 1 from 1

Material number: 4657.026.105

Plant: 465612000300

Material-assembly-group-no: 4656.120.003

6 WG 190 (Current date: 23.11.2012) /

PRESSURE REGULATOR

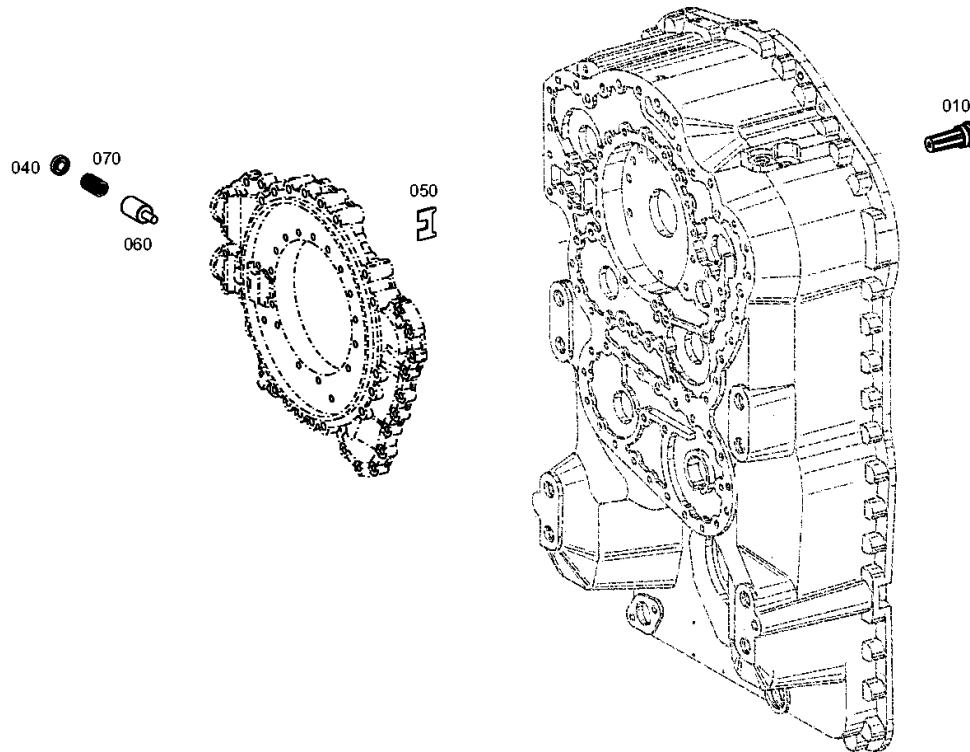

## Parts list

Page 1 from 1

Material number: 4657.026.105

6 WG 190 (Current date: 23.11.2012) /

Plant: 465612000300

Material-assembly-group-no: 4656.120.003



Pos.	Material number	Customer material	Name	Quantity	ME	Amend. no.	Techn. Info.	Weight	Rep kit	Alternative material
10	0501.211.384	9300061	VALVE	1		K00720/9810		0,084		
40	4656.306.077	T173145	PRESSURE PLATE	1				0,006		
50	4656.306.078	SA 8320-18970	TAB WASHER	1				20		
60	4656.306.107	SA 8320-27980	PISTON	1		K00720/9810		25		
70	0732.042.767	SA 8320-27710	COMPRSPRING	1		K00720/9810		36		

# Plant

Page 1 from 1

Material number: 4657.026.105

Plant: 465712200500

Material-assembly-group-no: 4657.122.005

6 WG 190 (Current date: 23.11.2012) /

PRESSURE OIL PUMP

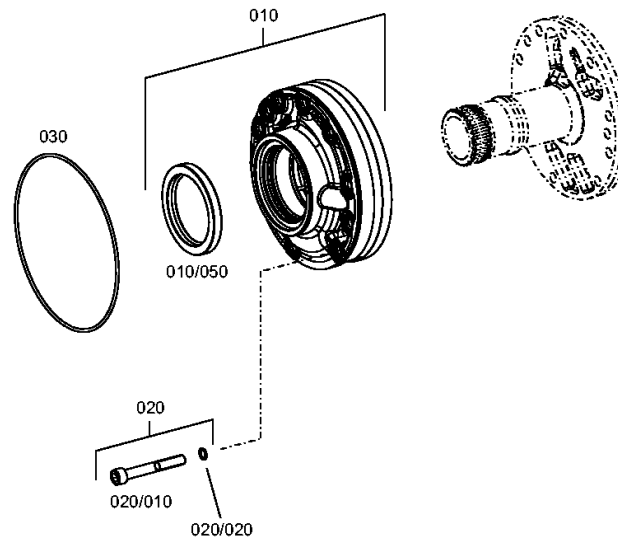

# Parts list

Page 1 from 1

Material number: 4657.026.105

6 WG 190 (Current date: 23.11.2012) /

Plant: 465712200500

Material-assembly-group-no: 4657.122.005



Pos.	Material number	Customer material	Name	Quantity	ME	Amend. no.	Techn. Info.	Weight	Rep kit	Alternative material
10	0501.214.895	42498812	GEAR PUMP	1			KPL.	6,369		
/50	0634.311.837	SA 8320-02380	SHAFT SEAL	1			75X95X10	45		
20	---	120705-00001	CAP SCREW	10				55		
/10	0636.101.120	SA 8320-27430	CAP SCREW	1			M10X75	52		
/20	0634.313.215	9301954	O-RING	1			9,5X1,6	0,100		
30	0634.313.999	SA 8320-27340	O-RING	1		K01165/0610	182X3	0,005		

# Plant

Page 1 from 1

Material number: 4657.026.105

Plant: 465613700400

Material-assembly-group-no: 4656.137.004

6 WG 190 (Current date: 23.11.2012) /

EMERGENCY STEERING PUMP

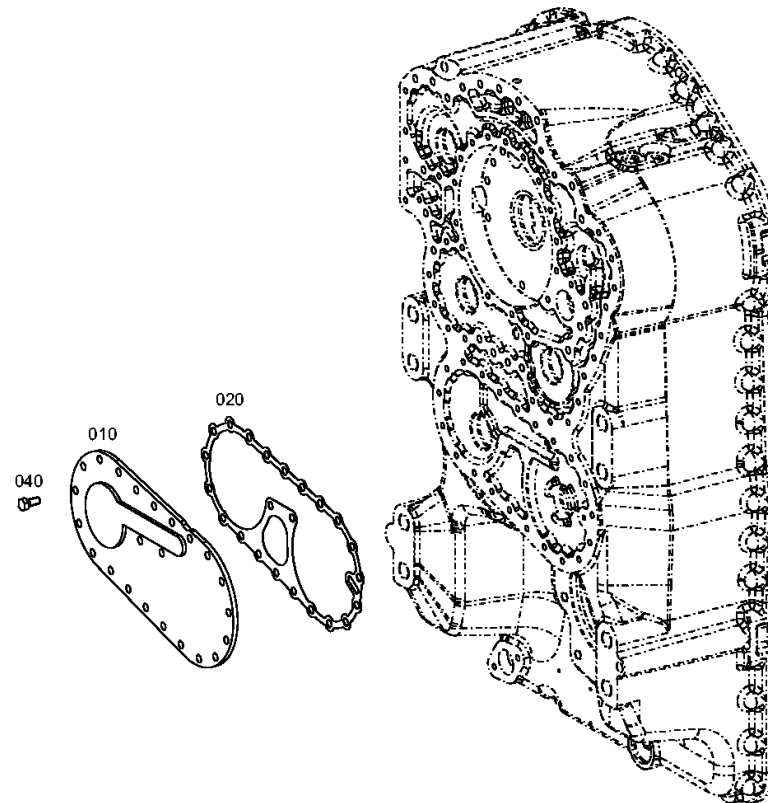

# Parts list

Page 1 from 1

Material number: 4657.026.105

6 WG 190 (Current date: 23.11.2012) /

Plant: 465613700400

Material-assembly-group-no: 4656.137.004



Pos.	Material number	Customer material	Name	Quantity	ME	Amend. no.	Techn. Info.	Weight	Rep kit	Alternative material
10	4656.337.005	110508-08589	COVER	1				2,090		
20	4656.337.010	9301958	GASKET	1		K00072/01110		10		
40	0636.015.225		HEXAGON BOLT	23			M8X18	10		

# Plant

Page 1 from 1

Material number: 4657.026.105

Plant: 465710700300

Material-assembly-group-no: 4657.107.003

6 WG 190 (Current date: 23.11.2012) /

SPEEDO

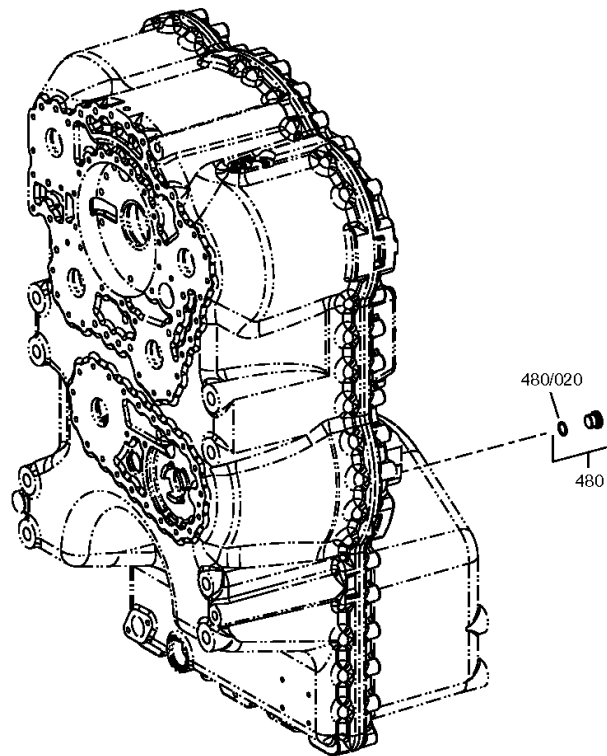



# Parts list

Page 1 from 1

Material number: 4657.026.105

6 WG 190 (Current date: 23.11.2012) /

Plant: 465710700300

Material-assembly-group-no: 4657.107.003



Pos.	Material number	Customer material	Name	Quantity	ME	Amend. no.	Techn. Info.	Weight	Rep kit	Alternative material
480	---	430221-00649	SCREW PLUG	1			M18X1,5 KPL.MIT O-RING	30		
/20	0634.306. 524	1000000292	O-RING	1			15X2	0,002		

# Plant

Page 1 from 1

Material number: 4657.026.105

Plant: 465712500200

Material-assembly-group-no: 4657.125.002

6 WG 190 (Current date: 23.11.2012) /

INDTRANSMITTER

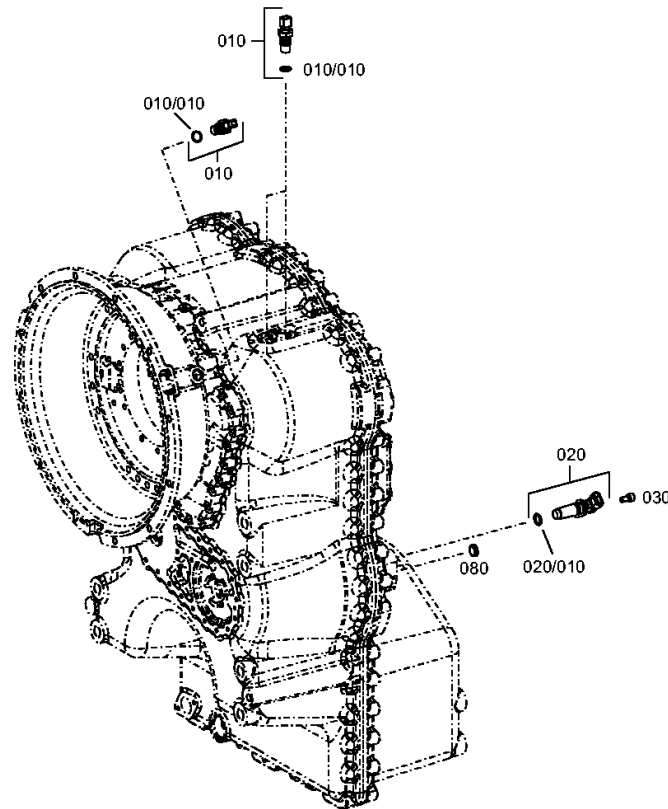

# Parts list

Page 1 from 1

Material number: 4657.026.105

6 WG 190 (Current date: 23.11.2012) /

Plant: 465712500200

Material-assembly-group-no: 4657.125.002



Pos.	Material number	Customer material	Name	Quantity	ME	Amend. no.	Techn. Info.	Weight	Rep kit	Alternative material
10	0501.209.719	9300062	INDTRANSMITTER	3		K00250/97110		0,055		
/10	0734.313.125	9303094	ROUND SEALING RING	1				0,002		
20	0501.317.949	9300063	SPEED TRANSMITTER	1		K02042/9910	ENTHALT.IN 0501 317 941(2)	0,040		
/10	0634.313.728	9300065	O-RING	1			15,54X2,62	0,001		
30	0636.101.680	SA 8320-03810	CAP SCREW	1			M8X16	12		
80	0501.318.288	1.119-00017	SEALING CAP	1				2		

# Plant

Page 1 from 1

Material number: 4657.026.105

Plant: 465712400300

Material-assembly-group-no: 4657.124.003

6 WG 190 (Current date: 23.11.2012) /

TEMPERATURE SENSOR

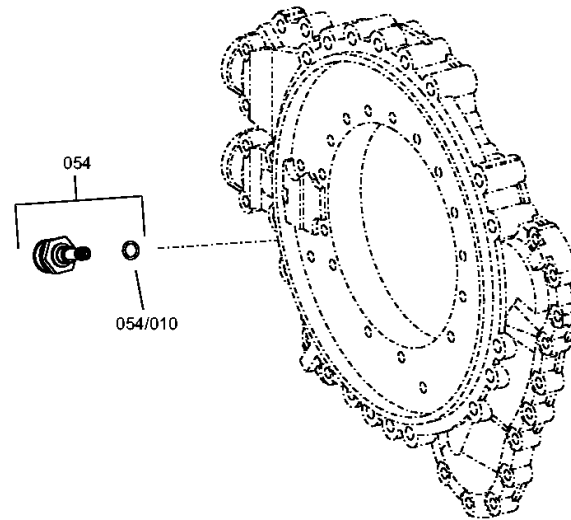

# Parts list

Page 1 from 1

Material number: 4657.026.105

6 WG 190 (Current date: 23.11.2012) /

Plant: 465712400300

Material-assembly-group-no: 4657.124.003



Pos.	Material number	Customer material	Name	Quantity	ME	Amend. no.	Techn. Info.	Weight	Rep kit	Alternative material
54	0501.322. 534		TEMPERATURE SENSOR	1		K00546/0610		90		
/10	0634.313. 366	SA 8320-27320	O-RING	1			11X2	0,030		

# Plant

Page 1 from 1

Material number: 4657.026.105

Plant: 465613801500

Material-assembly-group-no: 4656.138.015

6 WG 190 (Current date: 23.11.2012) /

FILTER

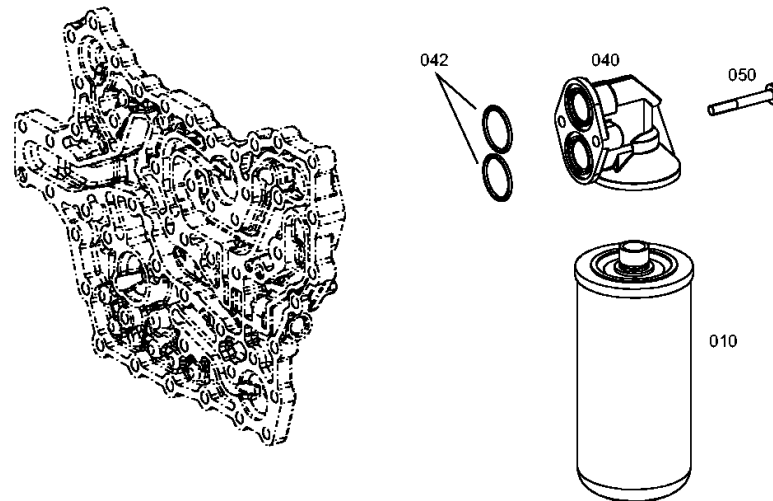

# Parts list

Page 1 from 1

Material number: 4657.026.105

6 WG 190 (Current date: 23.11.2012) /

Plant: 465613801500

Material-assembly-group-no: 4656.138.015



Pos.	Material number	Customer material	Name	Quantity	ME	Amend. no.	Techn. Info.	Weight	Rep kit	Alternative material
10	0501.323.154	VOE14507456	PRESSURE FILTER	1			KPL.	1,070		
40	0501.210.925		FILTER HEAD	1			KPL.	51		
42	0634.306.053	K9004018	O-RING	2		K01160/0610	34,2X3	0,005		
50	0736.101.335	SA 8320-07800	TORX SCREW	2			M8X60	27,200		

# Plant

Page 1 from 1

Material number: 4657.026.105

Plant: 465713100400

Material-assembly-group-no: 4657.131.004

6 WG 190 (Current date: 23.11.2012) /

FILLER NECK

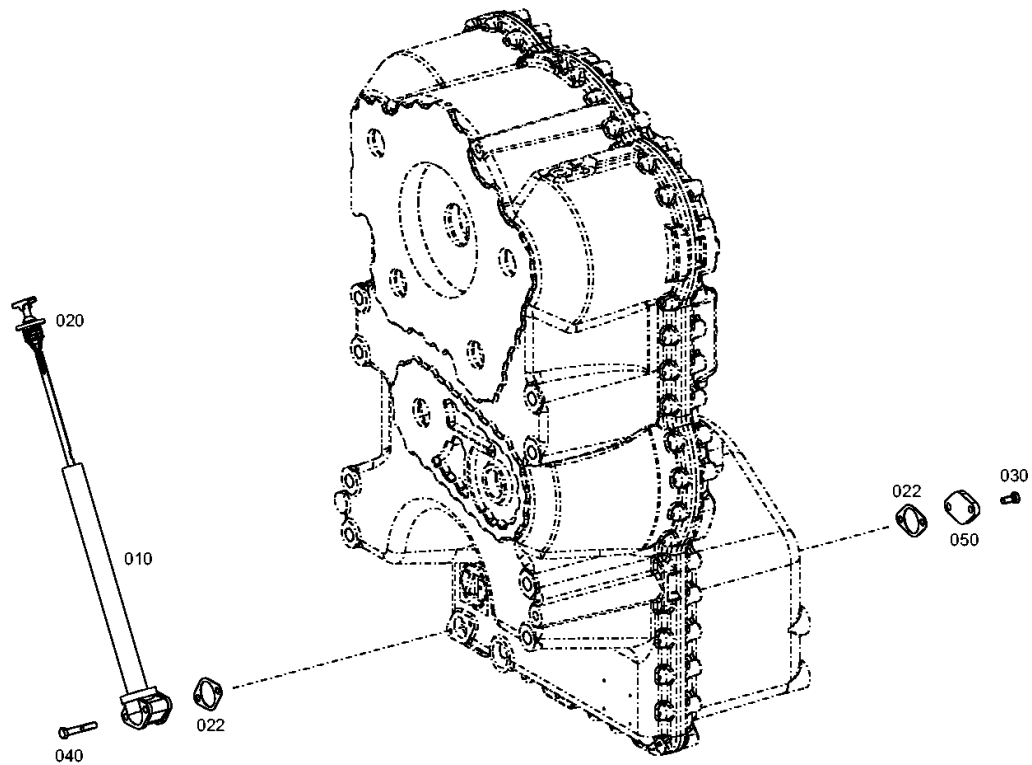



## Parts list

Page 1 from 1

Material number: 4657.026.105

6 WG 190 (Current date: 23.11.2012) /

Plant: 465713100400

Material-assembly-group-no: 4657.131.004



Pos.	Material number	Customer material	Name	Quantity	ME	Amend. no.	Techn. Info.	Weight	Rep kit	Alternative material
10	4642.231.127	00553559	OIL LEVEL TUBE	1				765		
20	4657.231.003	8900125383	OIL DIPSTICK	1				90		
22	4642.331.216	00553563	GASKET	2				0,001		
30	0636.015.225		HEXAGON BOLT	2			M8X18	10		
40	0636.010.741	9301446	HEXAGON BOLT	2			M8X50	25		
50	4644.301.014	ZM 2199250	COVER PLATE	1			E=8	12		

# Plant

Page 1 from 1

Material number: 4657.026.105

Plant: 465718315800

Material-assembly-group-no: 4657.183.158

6 WG 190 (Current date: 23.11.2012) /

LOOSE PARTS

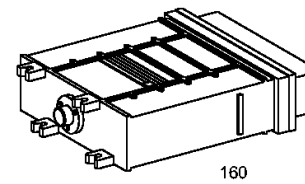
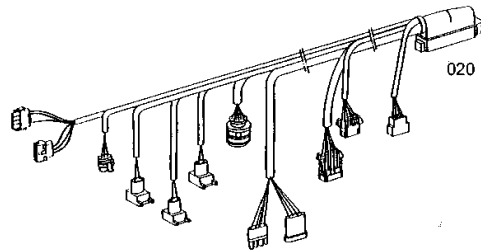
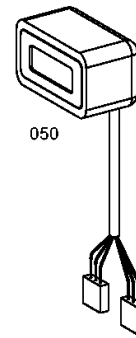
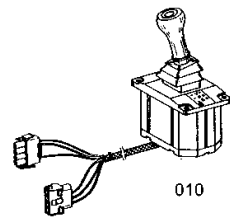

# Parts list

Page 1 from 1

Material number: 4657.026.105

6 WG 190 (Current date: 23.11.2012) /

Plant: 465718315800

Material-assembly-group-no: 4657.183.158



Pos.	Material number	Customer material	Name	Quantity	ME	Amend. no.	Techn. Info.	Weight	Rep kit	Alternative material
10	6006.035.005	9300072	FS VTS 3	1				1,400		
20	6029.017.060		CABLE OFF-ROAD	1			EST37 OFFENE STECKER LANG	2		
50	6007.203.237		DISPLAY	1			KPL. 2X4 POL.MATE- N-LOK	0,375		
120	6029.199.008	9300077	PLUG KIT	1			STECKER 4POL M-N- L BU	0,010		
130	6029.199.043	9300078	PLUG KIT	1			STECKER 22POL BU JUN.P.T.	0,025		
160	6009.092.698		CONTROL UNIT	1				1,130		