



SPARE PARTS CATALOGUE

0091 757 003c 07/2004

8S 1350

ZF Parts list n° 1295 095 074

customer: KAMAZ / RUS

ZF do Brasil Ltda.

parts list: 1295 095 074

8S-1350 / OD * LL*D-L H-H * KAMAZ / RUS

item	text	mod.no.
A10	CUSTOMER : KAMAZ	
	COUNTRY : RUS	
A14	CUST.SPEC.NO : NONE	
A16		
A90	RELEASE : FIRST INSTALLATION CHECK CARRIED OUT	
F06	INSTAL.POSITION:LH *FLANGE MOUNTED	
F10	RATIO 8,28 : 0,71 OD	
	8,28 * 5,69 * 2,90 * 2,03 * 1,40 * 1,00 * 0,71 * R6,70 *	
F26	PLANET GEAR SET : I=4,07*5 GEAR	
F34	CONTROL:REMOTE CONTROL *HORIZONTAL LH *H-H	
F38	SEPARAT.CLUCTH : SYNCHRONIZED 1+2/3+4 GEAR BK-SYNCHR.	
F40	INPUT SHAFT L=(283)109*SAE10C 2 INCH	
	JOURNAL: D=25 F7 * SHAFT : D=50,30 * BUSH : WITHOUT	
F46	REL.BRG.CARRIER: L=(167)-7*D=60 F8	
F50	OUTPUT : STANDARD BEARINGS	
F52	OUTP.FLANGE RA:OD=180 * BOLT = 4 X M14 X 1,50 X 50 L=208*	
F64	CONN.OF GEARSHIFT	
F66	CONTROL SHAFT DIMENSION : A=273,0	
F68	SHIFT LEVER : R1=90	
	CONTR.CONNECTION:POS.E*	
	OUTPUT ANGLE : Y = 13°	
F96	SET OF SPRINGS:LAYOUT Q1	
F98	PAWL STOP:SPRING FORCE RG=300N	
G16	SELECTION PATTERN : WI	
G30	SWITCH: RG*CLOSING *G.SHIFT SHAFT	
	PROTECTING CAP : WITH * BAYONET	
G32	SWITCH : NG * OPENING	
	PROTECTING CAP : WITH * BAYONET	
G36	SWITCH : GP * CLOSING *	
	PROTECTING CAP : WITH * BAYONET	

parts list: 1295 095 074

8S-1350 / OD * LL*D-L H-H * KAMAZ/ RUS

item	text	mod.no.
G60	AUXILIARY UNITS/ACCESSORIES	
G64	HEAT EXCHANGER : FRONT LEFT PREP.*	
G66	G.BOX VENTING : BREATHER	
G76	CLUTCH HOUSING : SAE 1* BOLTC CLUTCH FORK RELEASE :	
	WITH * L= 78 CYL : *L= *ASSEMBLY:6	
	HOLDING FIXTURE D= *SUSPENSION: ELETRONIC:	
	PULSE TRANSMITTER TACHO : IMP/U 6,00	
	TRANSMIT : WITH * PROTEC.CAP : WITH	
M00	DRAWING :	
M12	INSTALLATION : 1295 695 079 (A0)	
M14	SECTION : 0091 095 001 (A0)	
M16	SECTION : 1295 107 071 (A0)	
M18	SECTION : 0091 095 002 (A0)	
M50	ASSEMBLY INSTRUCTIONS :	
M58	ASSEMBLY : OIL FILL+OVERFLOW * HOUSING LEFT + RIGHT	
M82	ASSEMBLY : SHUT - OFF VALVE*F* THROTTLE :D=1,55	
M90	OIL CAPACITY : APROX. 14 L	
M92	OIL GRADE ACC. TO ZF :TE-ML 02	
M94	MASS APPRX. : 310,0KG	
M96	PAINT :DEEP BLACK * RAL 9005 ZFN915W	
M98	PRESERVATION : KA1 T/K12/ * ZFN916	
S02	VEHICLE DATA 1 :	
S04	MODEL:DUMPER(MULDE-)*KAMAZ 6520 6X4	
S06	MAX G.V.M. : 33T	
S08	DYN : 547*	
S10	RA : I=5,11 *	
S14	KAMAZ/ *KW 235/2200*N.M 1300/1300	
S68	CLUTCH : F&S * MF Z430	

parts list: 1295 095 074

8S-1350 / OD * LL*D-L H-H * KAMAZ / RUS

figure	part no.	description	technical information	mod.no.
0095 001 001	0091 101 215	GEARBOX HOUSING		
0095 001 002	0091 101 216	GEARBOX HOUSING		
0095 002 001	0091 102 190	INPUT SHAFT		
0095 003 001	0091 103 078	LAY SHAFT		
0095 004 001	0091 104 209	MAIN SHAFT		
0095 006 001	0091 106 095	GEAR SHIFT SYSTEM		
0095 007 001	0091 107 289	GEAR SHIFT SHAFT		
0095 070 001	0091 170 003	COVER		
0095 049 001	0091 149 027	SET OF SPRINGS		
0095 045 001	0091 145 002	RANGE SELECTION		
0095 900 001	0091 101 218	CLUTCH HOUSING		
0095 900 002	0091 101 221	CLUTCH HOUSING		
0095 031 001	0091 131 036	GP HOUSING		
0095 031 002	0091 131 037	COVER		
0095 032 001	0091 132 055	PLANETARY DRIVE		
0095 032 002	0091 132 056	PLANETARY DRIVE		
0095 033 001	0091 133 003	SYNCHRONIZER		
0095 034 001	0091 134 026	GP SHIFT SYSTEM		
0095 034 002	1295 134 426	CONN.PARTS		

parts list: 1295 095 074
figure: 0095 001 001

8S-1350 / OD * LL * D-L H-H * KAMAZ / RUS
GEARBOX HOUSING

*depending on parts list n°.

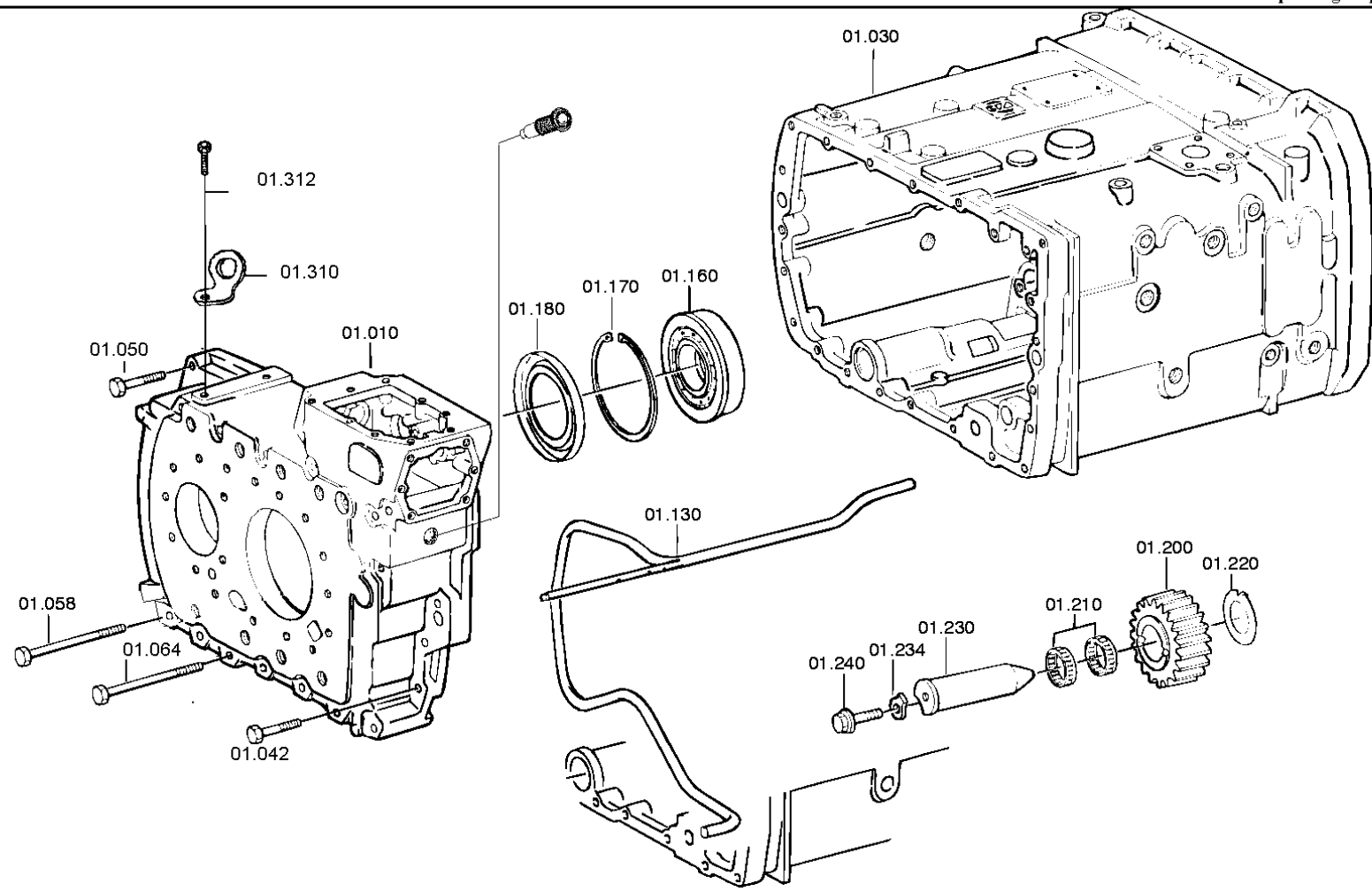

parts list: 1295 095 074
figure: 0095 001 002

8S-1350 / OD * LL * D-L H-H * KAMAZ / RUS
GEARBOX HOUSING

*depending on parts list n°.

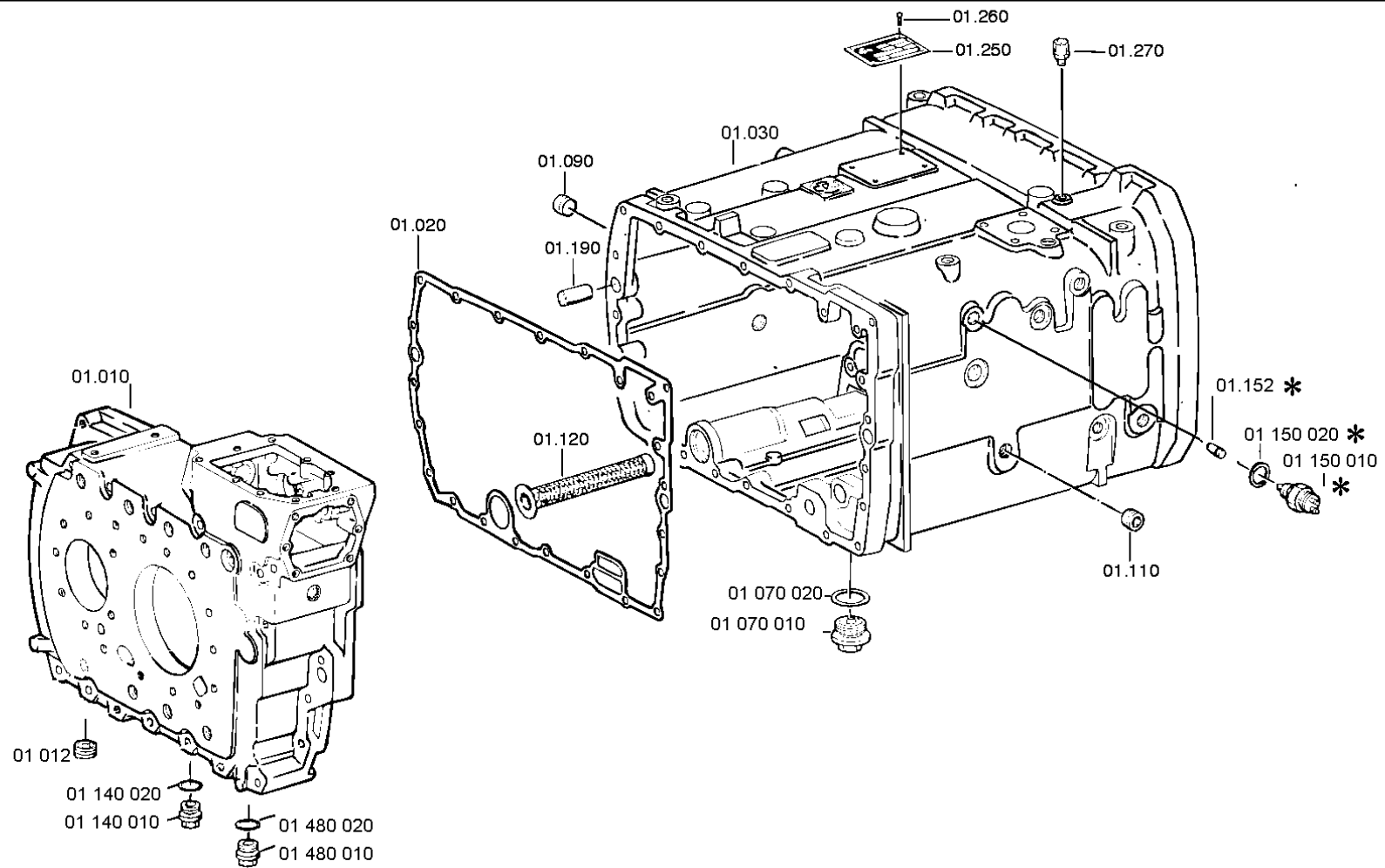

parts list: 1295 095 074
figure: 0095 001 001
0095 001 002

8S-1350 / OD * LL*D-L H-H * KAMAZ / RUS
GEARBOX HOUSING
GEARBOX HOUSING

FIG.	QTY.	PART-NUMBER	DESCRIPTION	OPT.	MOD.NO.	TECHNICAL INFORMATION
010	1	0091 301 136	HOUSING I			
012	1		SCREW PLUG			M24X1,5
	1	0736 303 005	SCREW PLUG			M24 X1,5
020	1	1313 301 038	GASKET			IN 1296 301 188 (A1)
030	1	0091 301 135	HOUSING II			8S=1350 KAMAZ
042	2		HEX CAP SCREW			M10X55 DIN 931 * 8.8
	2	0636 010 172	HEX CAP SCREW			M10X55 DIN 931 * 8.8
050	6		HEX CAP SCREW			M10X55 DIN 931 * 8.8
	6	0636 010 172	HEX CAP SCREW			M10X55 DIN 931 * 8.8
058	13		HEX CAP SCREW			M10X125 DIN 931 * 8.8
	13	0636 010 205	HEX CAP SCREW			M10X125 DIN 931 * 8.8
064	2		HEX CAP SCREW			M10X125 DIN 931 * 8.8
	2	0636 010 205	HEX CAP SCREW			M10X125 DIN 931 * 8.8
070	1		MAGNETIC SCREW PLUG			M38X1,5 * 140 N.M * SEALING RING
/010	1	0501 398 755	MAGNETIC SCREW PLUG		57775	M38X1,5 * MAGNET IN 0501 398 754
/020	1	0634 801 321	SEALING RING			A38x44 DIN 7603 AL
090	1		SCREW PLUG			M24X1,5
	1	0736 303 005	SCREW PLUG			M24X1,5
110	1		SCREW PLUG			M24X1,5
	1	0736 303 005	SCREW PLUG			M24X1,5 * 50,0 N.M
120	1	0501 308 398	FILTER			*IN 0501 308 398 (A3)
130	1	0091 201 038	SPRAY TUBE			CPL. * IN 0091 201 039 A0
140	1		SCREW PLUG			M22X1,5 * DIN 908 * ST * A3C
/010	1	0636 302 045	SCREW PLUG			M22X1,5 * 60,0 N.M SEALING RING
/020	1	0634 801 074	SEALING RING			A22X27 DIN 7603 CU
160	1	0750 118 153	ROLLER BEARING	X		WTB 60,0 X 130,0 X 31,0
170	1		RETAINING RING			WTB A= 3,70- 4,00 (THICKNESS RANGE 0,05MM.)
/010	1	0630 502 143	RETAINING RING			137X4 J137 FA /ORBIS
/020	1	0630 502 161	RETAINING RING			137X3,95 J FA /ORBIS 0

parts list: 1295 095 074
figure: 0095 001 001
0095 001 002

8S-1350 / OD * LL*D-L H-H * KAMAZ / RUS
GEARBOX HOUSING
GEARBOX HOUSING

FIG.	QTY.	PART-NUMBER	DESCRIPTION	OPT.	MOD.NO.	TECHNICAL INFORMATION
/030	1	0630 502 162	RETAINING RING			137X3,9 J FA./ORBIS
/040	1	0630 502 163	RETAINING RING			137X3,85 J FA./ORBIS
/050	1	0630 502 164	RETAINING RING			137X3,8 J FA./ORBIS
/060	1	0630 502 165	RETAINING RING			137X3,75 J FA./ORBIS
/070	1	0630 502 213	RETAINING RING			137X3,7 J FA./ORBIS
180	1	1295 304 129	OIL COLL.PLATE			1295 304 129 (A3)
190	2	0731 201 459	CYLINDRICAL PIN			IN 0731 201 458 (A1)
200	1	0091 305 014	SPUR GEAR REVERSE		57779	RE Z=24 * 0091 305 013
210	2	0750 115 011	NEEDLE CAGE	X		45X53X21 WTB
220	1	0730 150 064	THRUST WASHER			0730 150 064 (A4)
230	1	1295 305 056	REVERSE IDLER SHAFT			IN 1295 305 058 (A2)
234	1	1295 305 057	WASHER			1297 305 057 * (A2)
240	1		LOCKING SCREW			M12X35 * 150,0 N.M
	1	0501 308 588	HEX CAP SCREW			M12X35 *IN 0501 312 412 (A3)
250	1	0091 307 299	TYPE PLATE			DIN 1745
260	4	0501 398 460	BLIND RIVET			7,4X2,43
270	1		BREATHER			M10X1KEG
	1	0732 612 001	BREATHER			M10X1KEG
310	1	0091 301 114	SUPPORT PLATE GEAR SHIFT			0091 301 114
312	1	0636 015 264	HEX CAP SCREW			M10X20 ISO 4017 8.8 A3C
480	1		SCREW PLUG			M22X1,5 * 60,0 N.M *SEALING RING
/010	1	0636 302 045	SCREW PLUG			M22X1,5 * DIN 908 * ST A3C
/020	1	0634 801 074	SEALING RING			A22X27 DIN 7603 CU

parts list: 1295 095 074
figure: 0095 002 001

8S-1350 / OD * LL * D-L H-H * KAMAZ / RUS
INPUT SHAFT

* depending on parts list n°.

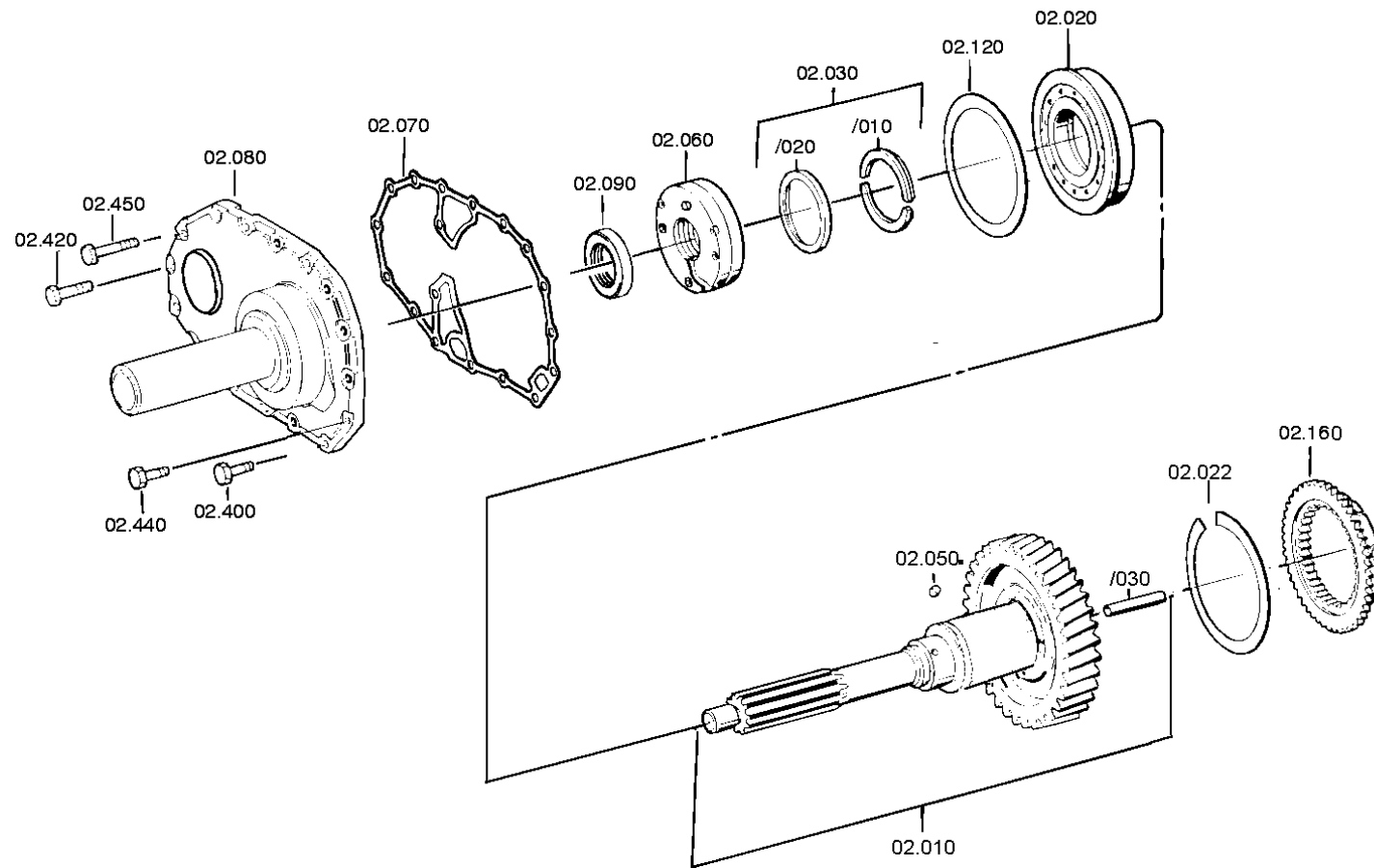

parts list: 1295 095 074
figure: 0095 002 001

8S-1350 / OD * LL* D-L H-H * KAMAZ / RUS
INPUT SHAFT

FIG.	QTY.	PART-NUMBER	DESCRIPTION	OPT.	MOD.NO.	TECHNICAL INFORMATION
010	1	0091 202 052	INPUT SHAFT			
/030	1	0730 062 323	PIPE			A=60,00 IN 0730 162 381 (A3)
020	1	0750 118 130	CY.ROLL.BEARING			WTB 80X150X27,5
022	1		RING		57776	A=200-420 (THICKNESS RANGE:0,20MM)WTB
	1	0501 398 751	RING			A=5,00 *IN 0501 398 737
	1	0501 398 750	RING			A=4,80 *IN 0501 398 737
	1	0501 398 749	RING			A=4,60 *IN 0501 398 737
	1	0501 398 748	RING			A=4,40 *IN 0501 398 737
	1	0501 398 746	RING			A=4,20 *IN 0501 398 737
	1	0501 398 745	RING			A=4,00 *IN 0501 398 737
	1	0501 398 744	RING			A=3,80 *IN 0501 398 737
	1	0501 398 743	RING			A=3,60 *IN 0501 398 737
	1	0501 398 741	RING			A=3,40 *IN 0501 398 737
	1	0501 398 739	RING			A=3,20 *IN 0501 398 737
030	1		SPLIT RING			WTB
/010	1	1295 202 034	SPLIT RING			KPL.GEST.ANZT.
	1		SPLIT RING			WTB A=3,80-4,00 (THICKNESS RANGE:0,10 MM)
	1	0730 105 156	SPLIT RING			A=4,00 *IN 0730 105 153 (A3)
	1	0730 105 155	SPLIT RING			A=3,90 *IN 0730 105 153 (A3)
	1	0730 105 154	SPLIT RING			A=3,80 *IN 0730 105 153 (A3)
/020	1	0730 062 579	RETAING RING		57781	A=4,20 IN 0730 062 636 (A2)
	1	0091 202 058	SPLIT RING			KPL.GEDREHT
/010	1		SPLIT RING			WTB 3,80-4,30(THICKNESS RANGE:0,05MM)
	1	0501 396 744	SPLIT RING			A=4,30*IN 0501 396 734
	1	0501 396 743	SPLIT RING			A=4,25*IN 0501 396 734
	1	0501 396 742	SPLIT RING			A=4,20*IN 0501 396 734
	1	0501 396 741	SPLIT RING			A=4,10*IN 0501 396 734
	1	0501 396 740	SPLIT RING			A=4,05*IN 0501 396 734
	1	0501 396 739	SPLIT RING			A=4,00*IN 0501 396 734

parts list: 1295 095 074
figure: 0095 002 001

8S-1350 / OD * LL* D-L H-H * KAMAZ / RUS
INPUT SHAFT

FIG.	QTY.	PART-NUMBER	DESCRIPTION	OPT.	MOD.NO.	TECHNICAL INFORMATION
	1	0501 396 738	SPLIT RING			A=4,95*IN 0501 396 734
	1	0501 396 737	SPLIT RING			A=4,90*IN 0501 396 734
	1	0501 396 736	SPLIT RING			A=4,85*IN 0501 396 734
	1	0501 396 745	SPLIT RING			A=4,80*IN 0501 396 734
/020	1	0501 398 753	RETAING RING			*IN 0501 398 753
050	1	0635 470 012	CYL.ROLLER			7X7 DIN 5402
060	1		PUMP		57836	WTB
	1	0091 202 057	PUMP			KPL.
	1	1295 202 035	PUMP			KPL.
	1	1269 202 087	PUMP			KPL.
070	1	1313 302 014	GASKET			1313 302 014 (A2)
080	1	0091 302 284	CONN.PLATE		57783	*IN 0091 302 287
090	1	0734 310 111	SHAFT SEAL			0734 310 111 (A2) FA.CFW.
120	1		SHIM			WTB 0730 107 221 (2) A=0,50-0,80 (THICKNESS RANGE:0,08MM)
	1	0730 103 804	SHIM			A=0,80 *IN 0730 107 221 (A1)
	1	0730 108 096	SHIM			A=0,75 *IN 0730 107 221 (A1)
	1	0730 102 505	SHIM			A=0,70 *IN 0730 107 221 (A1)
	1	0730 102 504	SHIM			A=0,60 *IN 0730 107 221 (A1)
	1	0730 102 503	SHIM			A=0,50 *IN 0730 107 221 (A1)
160	1	0091 304 311	CLUTCH BODY			ZF-BK 150
400	11		HEX CAP SCREW			M10X25 DIN 933 8.8
	11	0636 015 120	HEX CAP SCREW			M10X25 DIN 933 8.8
420	1		HEX CAP SCREW			M10X25 DIN 933 8.8
	1	0636 015 120	HEX CAP SCREW			M10X25 DIN 933 8.8
440	2		HEX CAP SCREW			M10X25 DIN 933 8.8
	2	0636 015 120	HEX CAP SCREW			M10X25 DIN 933 8.8
450	2		HEX CAP SCREW			M10X25 DIN 933 8.8
	2	0636 015 120	HEX CAP SCREW			M10X25 DIN 933 8.8

parts list: 1295 095 074
figure: 0095 003 001

8S-1350 / OD * LL * D-L H-H * KAMAZ / RUS
LAYSHAFT

*depending on parts list n°.

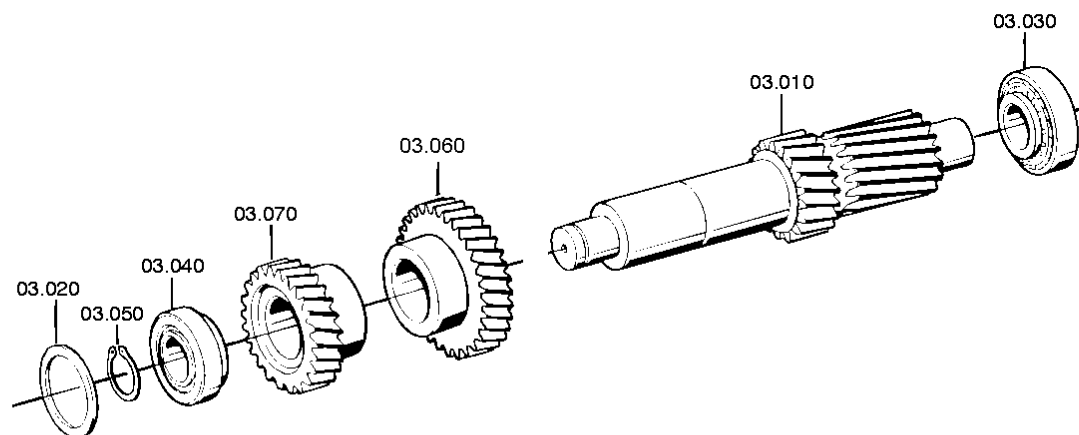

parts list: 1295 095 074
figure: 0095 003 001

8S-1350 / OD * LL* D-L H-H * KAMAZ / RUS
LAY SHAFT

FIG.	QTY.	PART-NUMBER	DESCRIPTION	OPT.	MOD.NO.	TECHNICAL INFORMATION
010	1	0091 303 155	INTERMEDIATE SHAFT			
020	1		SHIM			A=1,85-3,25(THICKNESS RANGE : 0,05MM) WTB
	1	0730 102 064	SHIM			A=2,40*IN 0730 106 702 (A1)
	1	0730 102 063	SHIM			A=2,45*IN 0730 106 702 (A1)
	1	0730 102 062	SHIM			A=2,50*IN 0730 106 702 (A1)
	1	0730 102 061	SHIM			A=2,55*IN 0730 106 702 (A1)
	1	0730 102 060	SHIM			A=2,60*IN 0730 106 702 (A1)
	1	0730 102 106	SHIM			A=2,65*IN 0730 106 702 (A1)
	1	0730 102 105	SHIM			A=2,70*IN 0730 106 702 (A1)
	1	0730 102 104	SHIM			A=2,75*IN 0730 106 702 (A1)
	1	0730 102 103	SHIM			A=2,80*IN 0730 106 702 (A1)
	1	0730 102 102	SHIM			A=2,85*IN 0730 106 702 (A1)
	1	0730 102 101	SHIM			A=2,90*IN 0730 106 702 (A1)
	1	0730 102 100	SHIM			A=2,95*IN 0730 106 702 (A1)
	1	0730 102 099	SHIM			A=3,00*IN 0730 106 702 (A1)
	1	0730 102 098	SHIM			A=3,05*IN 0730 106 702 (A1)
	1	0730 103 114	SHIM			A=3,10*IN 0730 106 702 (A1)
	1	0730 103 115	SHIM			A=3,15*IN 0730 106 702 (A1)
	1	0730 103 116	SHIM			A=3,20*IN 0730 106 702 (A1)
	1	0730 103 117	SHIM			A=3,25*IN 0730 106 702 (A1)
	1	0730 103 118	SHIM			A=3,30*IN 0730 106 702 (A1)
	1	0730 103 119	SHIM			A=3,35*IN 0730 106 702 (A1)
	1	0730 103 120	SHIM			A=3,40*IN 0730 106 702 (A1)
	1	0730 103 121	SHIM			A=3,45*IN 0730 106 702 (A1)
	1	0730 103 122	SHIM			A=3,50*IN 0730 106 702 (A1)
030	1	0750 117 008	TA.TOLL.BEARING	x		WTB 50X110X42,2 *IN 0750 117 008 (A3)
040	1	0750 117 010	TA.TOLL.BEARING	x		WTB 50,8X100X35 *IN 0750 117 010 (A3)
050	1		RETAINING RING			WTB A=2,10-3,20(THICKNESS RANGE :0,05MM)
	1	0630 501 151	RETAINING RING			50X3,2 DIN 471

parts list: 1295 095 074
figure: 0095 003 001

8S-1350 / OD * LL* D-L H-H * KAMAZ / RUS
LAY SHAFT

FIG.	QTY.	PART-NUMBER	DESCRIPTION	OPT.	MOD.NO.	TECHNICAL INFORMATION
	1	0630 501 298	RETAINING RING			50X3,15 DIN 471
	1	0630 501 150	RETAINING RING			50X3,1 DIN 471
	1	0630 501 299	RETAINING RING			50X3,05 DIN 471
	1	0630 531 065	RETAINING RING			50X3 DIN 471
	1	0630 501 111	RETAINING RING			50X2,95 DIN 471
	1	0630 501 112	RETAINING RING			50X2,9 DIN 471
	1	0630 501 113	RETAINING RING			50X2,85 DIN 471
	1	0630 501 114	RETAINING RING			50X2,8 DIN 471
	1	0630 501 115	RETAINING RING			50X2,75 DIN 471
	1	0630 501 116	RETAINING RING			50X2,7 DIN 471
	1	0630 501 117	RETAINING RING			50X2,65 DIN 471
	1	0630 501 118	RETAINING RING			50X2,6 DIN 471
	1	0630 501 160	RETAINING RING			50X2,55 DIN 471
	1	0630 531 064	RETAINING RING			50X2,5 DIN 471
	1	0630 501 159	RETAINING RING			50X2,45 DIN 471
	1	0630 501 148	RETAINING RING			50X2,4 DIN 471
	1	0630 501 294	RETAINING RING			50X2,35 DIN 471
	1	0630 501 147	RETAINING RING			50X2,3 DIN 471
	1	0630 501 295	RETAINING RING			50X2,25 DIN 471
	1	0630 501 146	RETAINING RING			50X2,2 DIN 471
	1	0630 501 296	RETAINING RING			50X2,15 DIN 471
	1	0630 501 145	RETAINING RING			50X2,1 DIN 471
060	1	0091 303 150	HELICAL GEAR			4M Z=31*IN 0091 303 149 (A1)
070	1	0091 303 153	HELICAL GEAR			3M Z=25 CTE.

parts list: 1295 095 074
figure: 0095 004 001

8S-1350 / OD * LL * D-L H-H * KAMAZ / RUS
MAIN SHAFT

*depending on parts list n°.

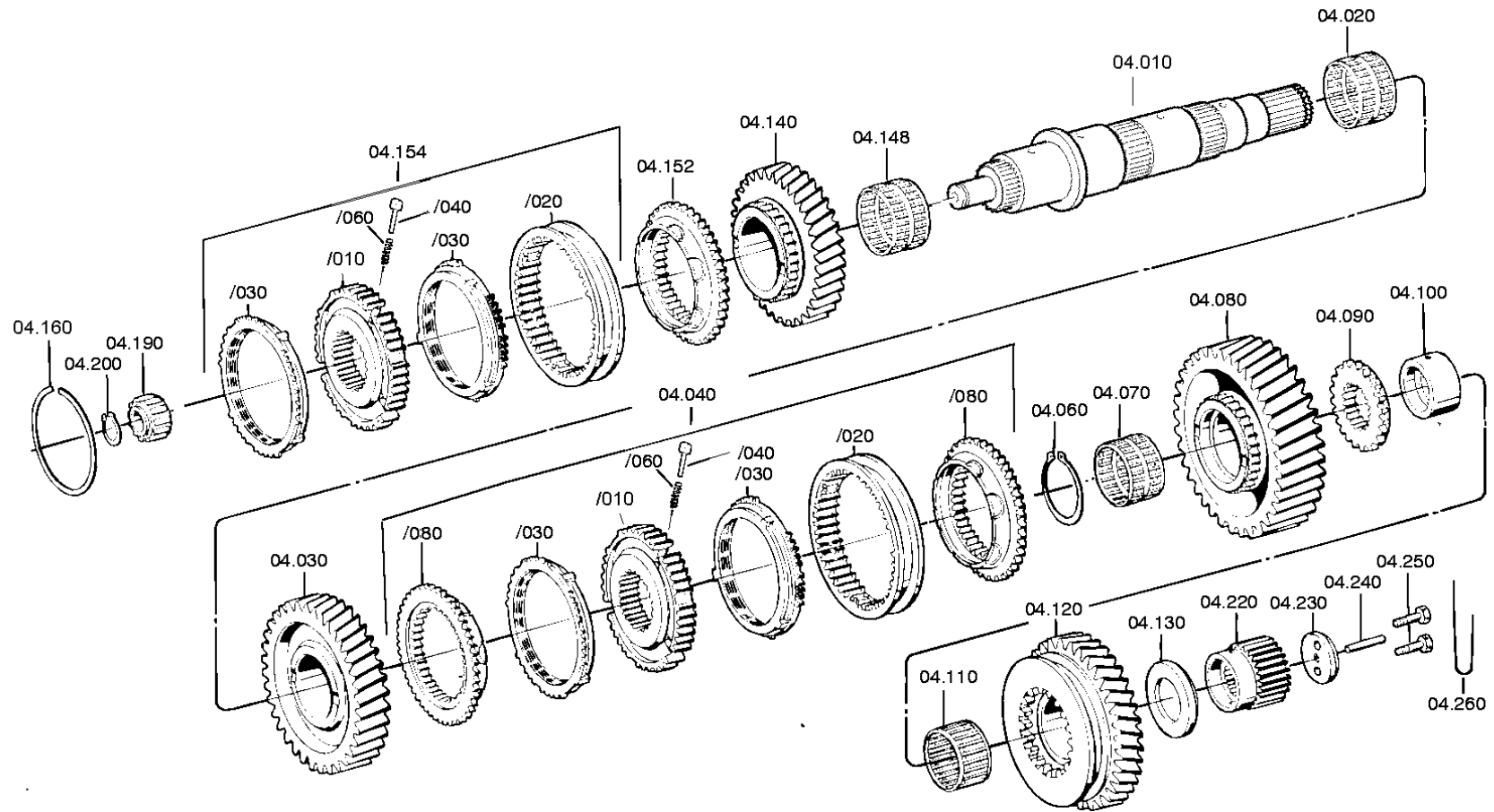

parts list: 1295 095 074
figure: 0095 004 001

8S-1350 / OD * LL* D-L H-H * KAMAZ / RUS
MAIN SHAFT

FIG.	QTY.	PART-NUMBER	DESCRIPTION	OPT.	MOD.NO.	TECHNICAL INFORMATION
010	1	0091 304 333	MAIN SHAFT			0091 304 333 (A1)
020	1	0750 115 283	NEEDLE CAGE			80X88X46 0750 115 283 WTB
030	1	0091 304 114	HELICAL GEAR		57778	2 ^a M Z=38 *IN 0091 304 344
040	1	1316 204 013	SYNCHRONIZER			KPL.1+2M * BK * D160
/010	1	1316 304 152	SYNCHRONIZER BODY			ZF-BK160 *IN 1316 304 151 (A1)
/020	1	1315 304 136	SLIDING SLEEVE			ZF-BK 165 / 130.hs 145
/030	2	1316 304 150	SYNCHRONIZER RING			D=160 ZF-BK150
/040	3	1297 304 436	PRESSURE PIECE			*IN 1268 304 509 (2)
/060	3	0732 040 409	COMPRESSION SPRING			
/080	2	1316 304 154	CLUTCH BODY			ZF-BK160*IN 1316 304 153 (A1)
060	1		RETAINING RING			A= 2,00-2,50 (THICKNESS RANGE :0,10MM)
	1	0630 501 050	RETAINING RING			80X2,5 DIN 471
	1	0630 531 300	RETAINING RING			80X2,4 DIN 471
	1	0630 531 301	RETAINING RING			80X2,3 DIN 471
	1	0630 501 304	RETAINING RING			80X2,2 DIN 471
070	1	0735 320 496	NEEDLE CAGE			70X78X55 FA.INA F-88956
080	1	0091 304 334	HELICAL GEAR			1M Z=47
090	1	1295 304 206	CLUTCH BODY			RE *IN 1295 304 152 (A1)
100	1	1295 304 012	BUSH			RE
110	1	0750 115 059	NEEDLE CAGE			75X83X40 WTB
120	1	0091 304 335	GEAR REVERSE			RE Z=38 0091 304 335 (A1)
130	1	1295 304 240	THRUST WASHER			*IN 1295 304 239 (A2)
140	1	0091 304 330	HELICAL GEAR			4 ^a M Z=30 *IN 0091 304 329 (A1)
148	1	0750 115 283	NEEDLE CAGE			80X88X46 WTB
152	1	0091 304 310	CLUTCH BODY			ZF-BK-150
154	1	0091 204 033	SYNCHRONIZER			KPL * 3+4M * BK * 150
/010	1	1312 304 052	SYNCHRONIZER BODY			ZF-BK150 *IN 1296 304 148 (A1)
/020	1	1310 304 225	SLIDING SLEEVE			ZF-BK150
/030	2	1297 304 484	SYNCHRONIZER RING			ZF-BK150 1297 304 484 (A1)

parts list: 1295 095 074
 figure: 0095 004 001

8S-1350 / OD * LL* D-L H-H * KAMAZ / RUS
 MAIN SHAFT

FIG.	QTY.	PART-NUMBER	DESCRIPTION	OPT.	MOD.NO.	TECHNICAL INFORMATION
/040	3	1297 304 436	PRESSURE PIECE			*IN 1268 304 509 (A2)
/050	3	0732 040 409	COMPRESSION SPRING			
160	1		RETAINING RING			A= 2,10- 2,50 (THICKNESS RANGE 0,10MM) WTB
	1	0630 501 050	RETAINING RING			80X2,5 DIN 471
	1	0630 531 300	RETAINING RING			80X2,4 DIN 471
	1	0630 531 301	RETAINING RING			80X2,3 DIN 471
	1	0630 501 304	RETAINING RING			80X2,2 DIN 471
190	1	0750 118 038	CY.ROLL BEARING			35,0X68,0X27,5 WTB
200	1	0630 501 028	RETAINING RING			35X1,5 DIN 471
220	1	0091 304 194	SUN GEAR		57833	SOLAR Z=27 *IN 0091 304 346
230	1	0091 304 291	FIXING WASHER			*IN 0091 304 289 (A3)
240	1	0730 061 842	PIPE			A=50,00
250	2		HEXAGON SCREW			M10X30 SK*DIN 933*10.9
	2	0636 010 240	HEXAGON SCREW			M10X30 SK*DIN 933*10.9
260	3	0501 099 730	WIRE 1,24MM			1,4 MM EN 10218 (C4D N)

parts list:
figure:

1295 095 074
0095 006 001

8S-1350 / OD * LL * D-L H-H * KAMAZ / RUS
GEARSHIFT SYSTEM

*depending on parts list n°.

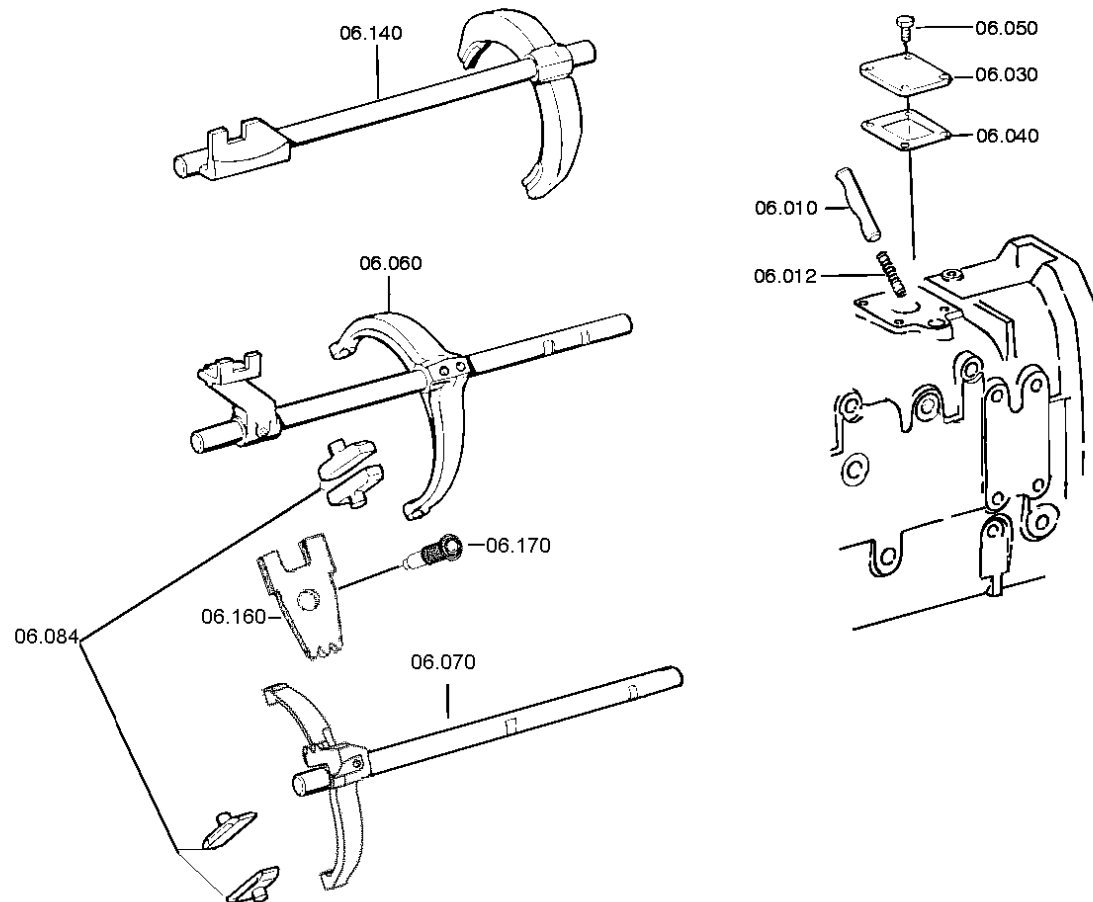

parts list: 1295 095 074
 figure: 0095 006 001

8S-1350 / OD * LL* D-L H-H * KAMAZ / RUS
 GEAR SHIFT SYSTEM

FIG.	QTY.	PART-NUMBER	DESCRIPTION	OPT.	MOD.NO.	TECHNICAL INFORMATION
010	1	1313 306 013	LOCKING PIN			1313 306 013 (A1)
012	1	0732 040 736	COMPR.SPRING			0732 040 736 (A3)
030	1	7315 003 185	FLANGE			7315 003 185 (A3)
040	1	1313 306 012	GASKET			1313 306 012 (A2)
050	4		HEX CAP SCREW			M8X16 * ISO 4017/ZFB 988 * 8.8
	4	0636 015 278	HEX CAP SCREW			M8X16 * ISO 4017/ZFB 988 * 8.8
060	1	0091 206 060	GEAR SHIFT RAIL			KPL - 1 ^a +2 ^a M - WI
064	2	1297 306 120	SLIDING PAD			0091 306 076 (A3)
070	1	0091 206 058	GEAR SHIFT RAIL			KPL - 3 ^a +4 ^a M - WI
084	2	1297 306 120	SLIDING PAD			*IN 1240 306 248 (A3)
140	1	0091 206 059	GEAR SHIFT RAIL			RE - WI KPL.
160	1	0091 306 076	RELAY LEVER			0091 306 076 (A1)
170	1	0091 306 079	ARTICULAT. BOLT			0091 306 079 (A2)

parts list: 1295 095 074
figure: 0095 007 001

8S-1350 / OD * LL * D-L H-H * KAMAZ / RUS
G.SHIFT SHAFT

*depending on parts list n°.

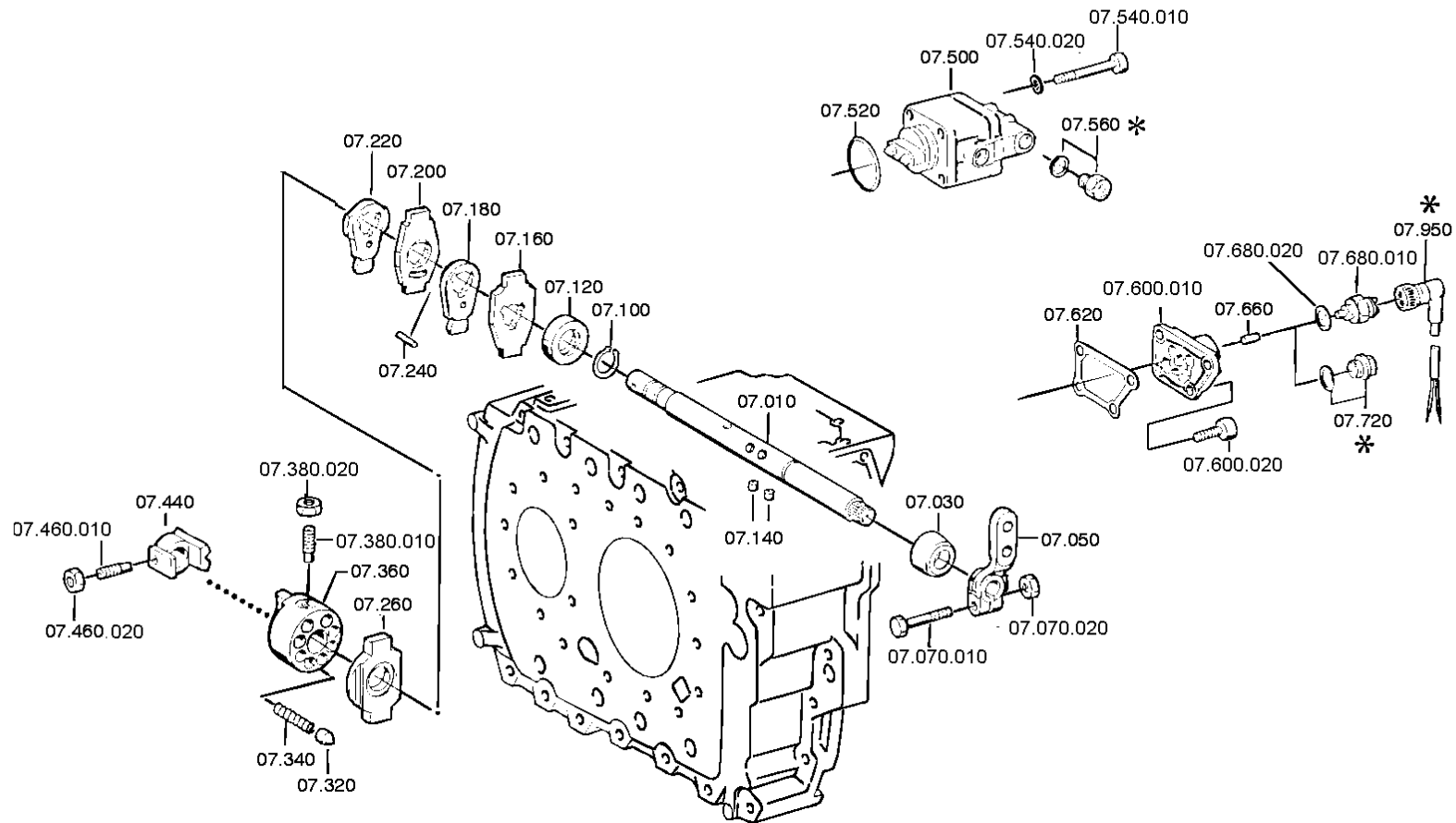

parts list: 1295 095 074
figure: 0095 007 001

8S-1350 / OD * LL* D-L H-H * KAMAZ / RUS
G. SHIFT SHAFT

FIG.	QTY.	PART-NUMBER	DESCRIPTION	OPT.	MOD.NO.	TECHNICAL INFORMATION
010	1	0091 307 304	GEAR SHIFT SHAFT		57503	*IN 0091 307 111 (A1)
030	1	1238 307 411	PROTECTING CAP			*IN 1304 307 093 (A2)
050	1	0091 307 307	GEAR SHIFT LEVER		58073	*IN 0091 307 233 (A1)
070	1		HEXAGON SCREW			M10X40*DIN 933/ZFB988*10.9 A3C
/010	1	0636 015 469	HEXAGON SCREW			M10X40*DIN 933/ZFB988*10.9 A3C
/030	1	0637 006 120	HEXAGON NUT			M10 DIN 934 A3C
100	1	0630 532 205	SNAP RING			JV 27 FA.ORBIS/ZFB987
120	1		WASHER			SINT. ER/ STAHL WTB
/010	1	1295 307 379	WASHER			*IN 1295 307 378 (A2)
/020	1	1295 307 250	WASHER			*IN 1295 307 249 (A2)
140	6	0735 470 007	ROLLER			*IN 0735 470 157 (A2)
160	1	0091 307 297	SKID PIECE			0091 307 297 (A2)
180	1	0091 307 296	DRIVER			0091 307 296 (A1)
200	1	0091 307 298	SKID PIECE			*IN 0091 380 071 (A3)
220	1	0091 307 295	DRIVER			0091 307 295 (A1)
240	1	0091 380 071	CYLINDRICAL PIN			0091 380 071 (A3)
260	1	0091 307 197	SKID PIECE			0091 307 197 (A2)
320	8	1295 307 243	STOP BOLT			*IN 1238 306 281 (A2)
340	8	0732 040 736	COMPR.SPRING			0732 040 736 (A3)
360	1	1295 307 409	STOP PART			*IN 1295 307 258 (A1)
380	1		THREADED BOLT			M12X1,5
/010	1	0501 398 399	THREADED BOLT			M12X1,5 IN 0501 398 397 (A3)
/020	1	0637 002 039	HEXAGON NUT			BM 12X1,5 DIN 439/ZFB999 06
440	1	0091 307 219	STOP PART			*IN 0091 307 220 (A2)
460	1		THREADED BOLT			M12X1,5
/010	1	0501 398 398	THREADED BOLT			M12X1,5
/020	1	0637 002 039	HEXAGON NUT			BM 12X1,5 DIN 439/ZFB999 06
500	1		CUT -OFF VALVE			WTB
	1	6038 202 003	CUT -OFF VALVE			KPL.

parts list: 1295 095 074
figure: 0095 007 001

8S-1350 / OD * LL* D-L H-H * KAMAZ / RUS
G. SHIFT SHAFT

FIG.	QTY.	PART-NUMBER	DESCRIPTION	OPT.	MOD.NO.	TECHNICAL INFORMATION
520	1	0634 314 021	O-RING			36,2X3 ZFN 744
540	4		CAP SCREW			M8X60*ISO 4762*8.8 * A3C
/010	4	0636 101 664	CAP SCREW			M8X60*ISO 4762*8.8 * A3C
/020	4	0630 302 090	SPRING WASHER			B8 DIN 137 FST FE/ZN8C
600	1	1295 207 034	COVER			KPL.
/010	1	0091 307 149	COVER			0091 307 149 (A1)
/020	4	0636 015 084	HEX CAP SCREW			M8X22 ISO 4017 8.8
620	1	1313 307 002	GASKET			1313 306 002 (A3)
660	1	0731 201 393	PIN			0731 201 393 (A3)
680	1		SWITCH			SCHL * 45N.M* SEALING RING
/010	1	0501 210 058	SWITCH			0501 210 058 (A1)
/020	1		SEALING RING			A=0,80-2,00(THICKNESS RANGE:0,20MM)
	1	0730 150 302	SEALING RING			A=2,00 *IN 0730 150 439 (A2)
	1	0730 150 160	SEALING RING			A=1,80 *IN 0730 150 439 (A2)
	1	0730 150 219	SEALING RING			A=1,60 *IN 0730 150 439 (A2)
	1	0730 150 220	SEALING RING			A=1,40 *IN 0730 150 439 (A2)
	1	0730 150 162	SEALING RING			A=1,20 *IN 0730 150 439 (A2)
	1	0730 150 248	SEALING RING			A=1,00 *IN 0730 150 439 (A2)
	1	0730 150 249	SEALING RING			A=0,80 *IN 0730 150 439 (A2)

parts list: 1295 095 074
figure: 0095 070 001

8S-1350 / OD * LL * D-L H-H * KAMAZ / RUS
COVER

*depending on parts list n°.

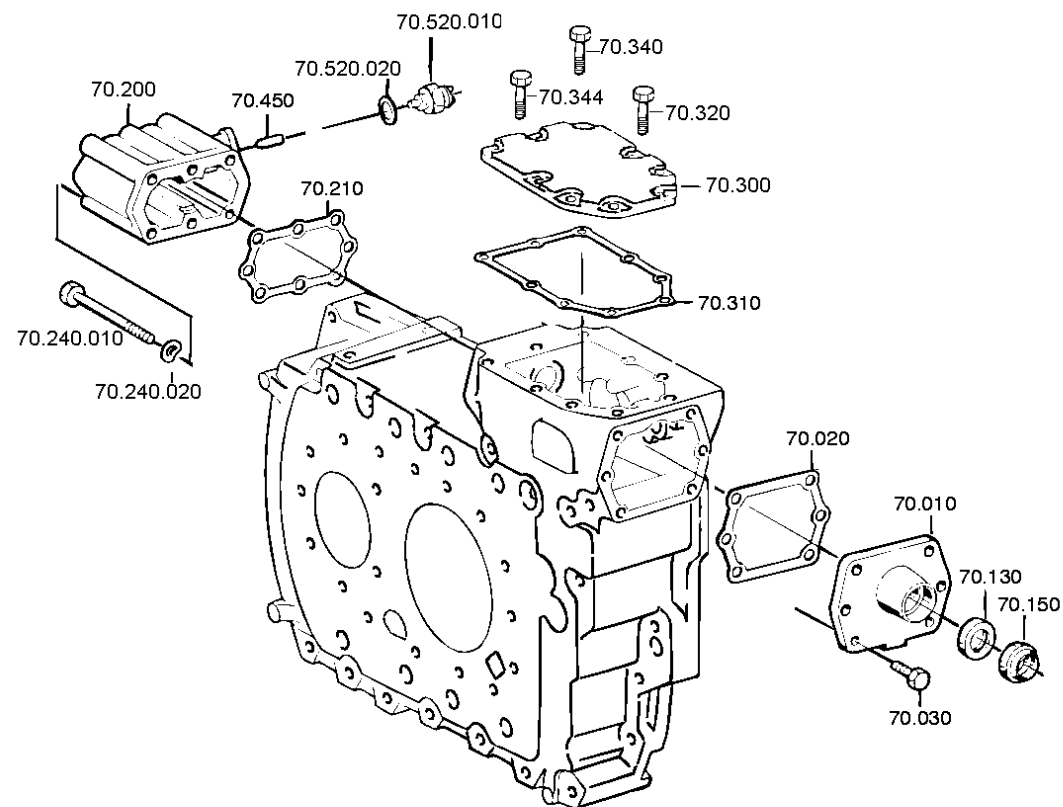

parts list: 1295 095 074

figure: 0095 070 001

8S-1350 / OD * LL* D-L H-H * KAMAZ / RUS

COVER

FIG.	QTY.	PART-NUMBER	DESCRIPTION	OPT.	MOD.NO.	TECHNICAL INFORMATION
010	1	1295 307 434	COVER			*IN 1295 307 433 (A1)
020	1	1313 307 020	GASKET			*IN 1295 307 633 (A2)
030	6		HEXAGON SCREW			M8X22 * ISO 4017 * 8.8
/010	6	0636 015 084	HEXAGON SCREW			M8X22 * ISO 4017 * 8.8
130	1	0634 300 302	SHAFT SEAL			25X35X7 B ZFN 132 NB
150	1	0634 307 367	ROD WIPER			AS25X35X7X10 FA.CFW 88NBR/101
200	1	0091 307 153	COVER			0091 307 153 (A1)
210	1	1313 307 004	GASKET			1313 307 004 (A3)
240	6		HEXAGON SCREW			M8X105 * ISO 4014*8.8
/010	6	0636 010 121	HEXAGON SCREW			M8X105 * ISO 4017*8.8
/020	1	0630 302 090	SPRING WASHER			B8 DIN 137 FST FE/ZN8C
300	1	0091 307 500	COVER			0091 307 500 (A1)
310	1	1313 307 003	GASKET			1313 307 003 (A2)
320	6		HEXAGON SCREW			M8x18 * ISO 4017 * 8.8
/010	6	0636 015 073	HEXAGON SCREW			M8X18 * ISO 4017 * 8.8
340	2		HEXAGON SCREW			M8x18 * ISO 4017 * 8.8
/010	2	0636 015 073	HEXAGON SCREW			M8X18 * ISO 4017 * 8.8
344	1		HEXAGON SCREW			M8x22 * ISO 4017 * 8.8
/010	1	0636 015 084	HEXAGON SCREW			M8X22 * ISO 4017 * 8.8
450	1	0731 208 062	PIN			*IN 0731 208 100 (A2)
520	1		SWITCH			OEFF * 45,0 N.M SEALING RING
/010	1	0501 210 059	SWITCH			KLP 0501 210 059 (A2)
/020	1	0634 801 062	SEALING RING			A18X24 DIN 7603 AL

parts list: 1295 095 074
figure: 0095 049 001

8S-1350 / OD * LL * D-L H-H * KAMAZ / RUS
SET OF SPRINGS

*depending on parts list n°.

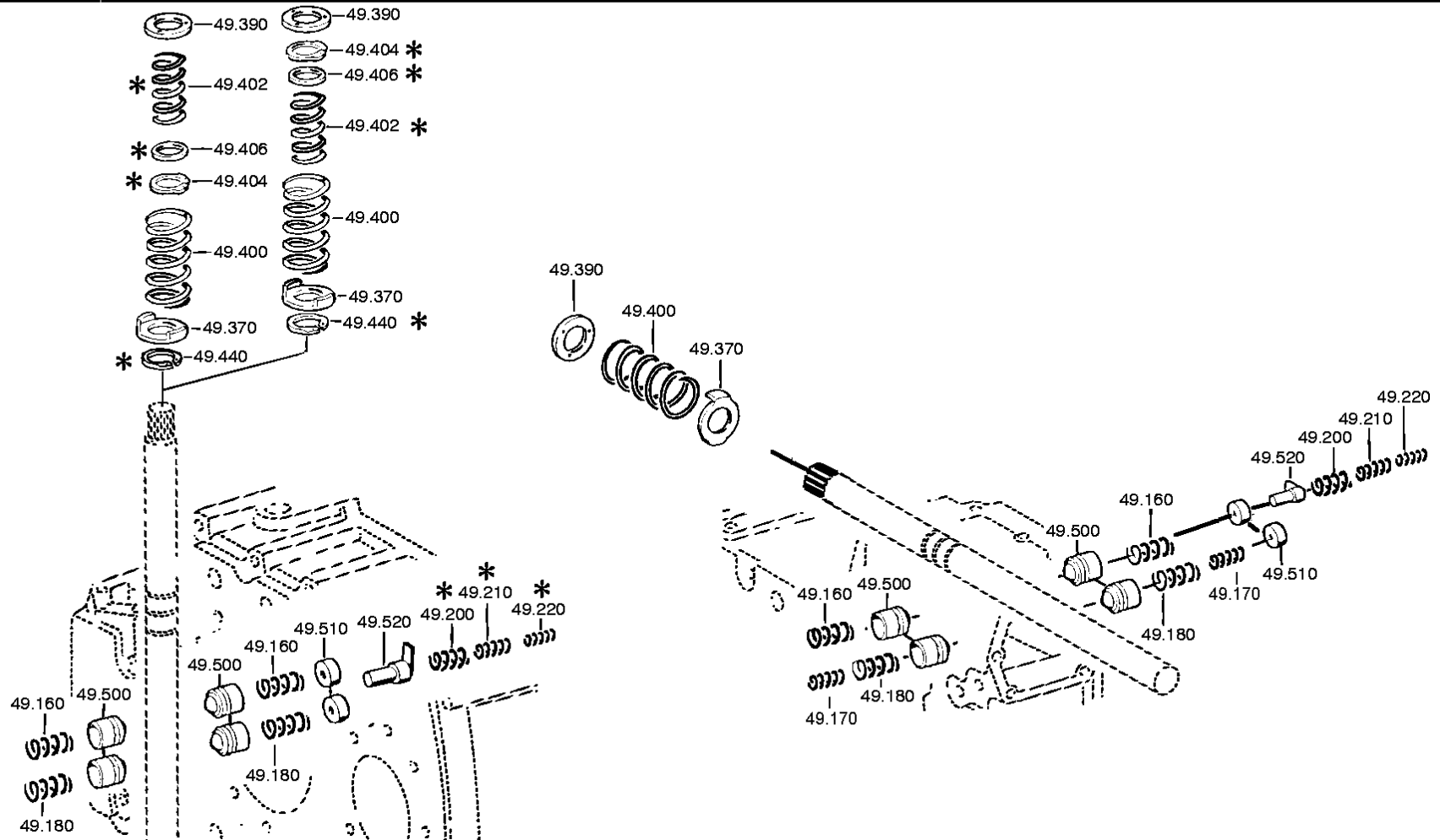

parts list: 1295 095 074

figure: 0095 049 001

8S-1350 / OD * LL* D-L H-H * KAMAZ / RUS

SET OF SPRINGS

FIG.	QTY.	PART-NUMBER	DESCRIPTION	OPT.	MOD.NO.	TECHNICAL INFORMATION
160	2	0732 040 986	COMPR.SPRING			0732 040 986 (A3)
170	2	0732 040 984	COMPR.SPRING			0732 040 984 (A3)
180	2	0732 041 500	COMPR.SPRING			0732 041 500 (A3)
200	1	0732 040 986	COMPR.SPRING			0732 040 986 (A3)
210	1	0732 040 984	COMPR.SPRING			0732 040 984 (A3)
220	1	0732 040 983	COMPR.SPRING			0732 040 983 (A3)
370	1	1295 307 522	WASHER			*IN 1295 307 519 (A2)
390	1	0730 104 083	WASHER			A=2,00 *IN 0730 104 527 (A2)
400	1	0732 040 765	COMPR.SPRING			0732 040 765 (A3)
500	4	0750 115 335	BALL ROLLER			WTB
510	2	0730 062 448	BUSH			A=11,00 *IN 0730 062 845 (A3)
520	1	0091 307 163	BOLT			0091 307 163 (A3)

parts list: 1295 095 074
figure: 0095 045 001

8S-1350 / OD * LL * D-L H-H * KAMAZ / RUS
RANGE SELECTION

*depending on parts list n°.

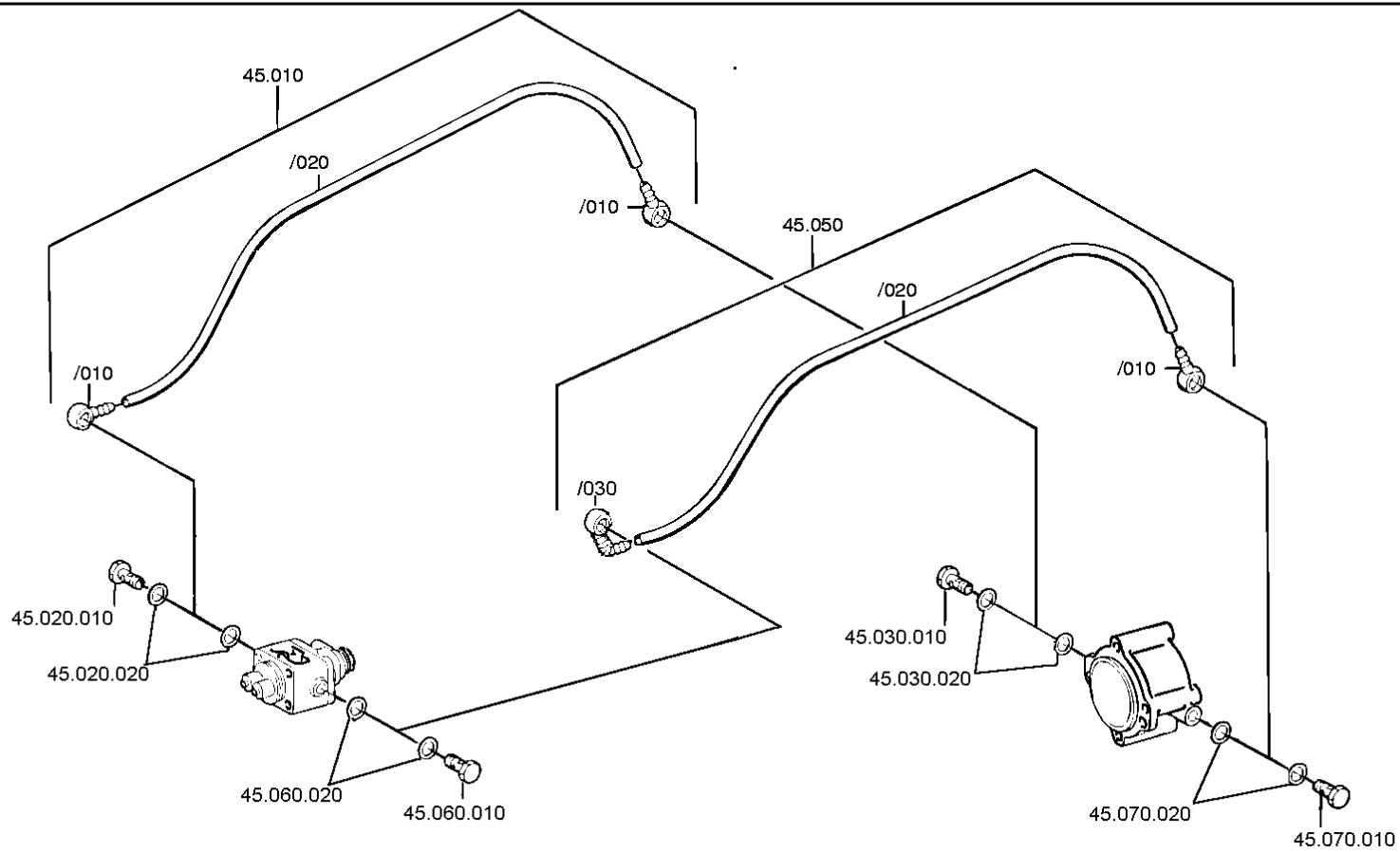

parts list: 1295 095 074
figure: 0095 045 001

8S-1350 / OD * LL* D-L H-H * KAMAZ / RUS
RANGE SELECTION

FIG.	QTY.	PART-NUMBER	DESCRIPTION	OPT.	MOD.NO.	TECHNICAL INFORMATION
010	1	0091 202 053	TECALAN TUBE			480 MM
/010	2	0750 146 953	RING NAPPLE			WTB
/020	1	0632 702 528	TECALAN TUBE			12X2 DIN 73378 PA11W SW LT ME
020	1		UNION SCREW			DIN 7643 10
/010	1	0637 835 515	UNION SCREW			10 * DIN 7643 * ZFB 817
/020	2	0634 801 260	SEALING RING			A14X18 * DIN7603 * AL
030	1		UNION SCREW			DIN 7643 10
/010	1	0637 835 515	UNION SCREW			10 * DIN 7643 * ZFB 817
/020	2	0634 801 260	SEALING RING			A14X18 * DIN 7603 *AL
050	1	0091 202 054	TECALAN TUBE			480 MM KPL.
/010	1	0750 146 953	RING NAPPLE			WTB
/020	1	0632 702 528	TECALAN TUBE			12X2 DIN 73378 PA11W SW LT ME
/030	1	0501 396 701	RING NAPPLE			FA. SPART.
060	1		UNION SCREW			DIN 7643 10
/010	1	0637 835 515	UNION SCREW			10 * DIN 7643/ZFB 817
/020	2	0634 801 260	SEALING RING			A14X18 DIN 7603 AL
070	1		UNION SCREW			DIN 7643 10
/010	1	0637 835 515	UNION SCREW			10 * DIN 7643/ZFB 817
/020	2	0634 801 260	SEALING RING			A14X18 DIN 7603 AL

parts list: 1295 095 074
figure: 0095 900 001

8S-1350 / OD * LL * D-L H-H * KAMAZ / RUS
CLUTCH HOUSING

*depending on parts list n°.

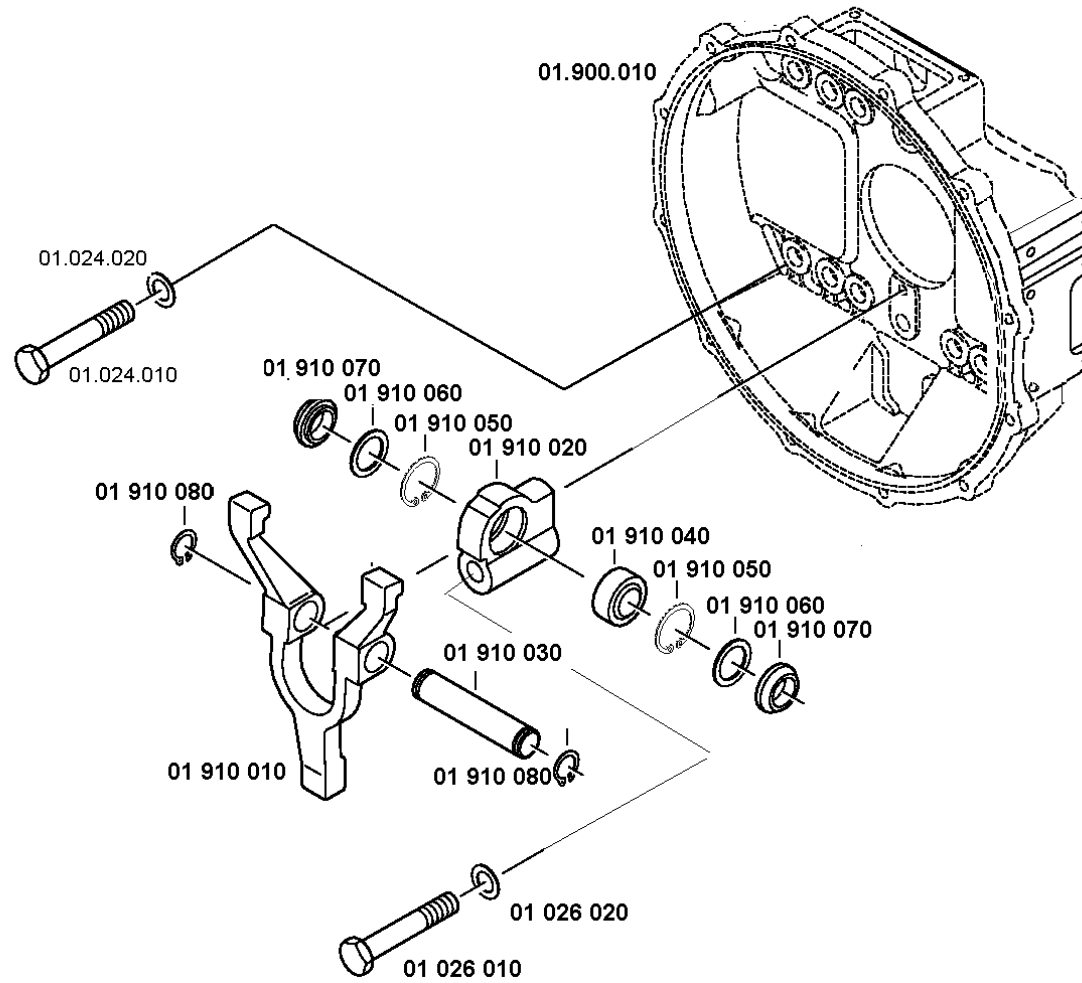

parts list: 1295 095 074
figure: 0095 900 002

8S-1350 / OD * LL * D-L H-H * KAMAZ / RUS
CLUTCH HOUSING

*depending on parts list n°.

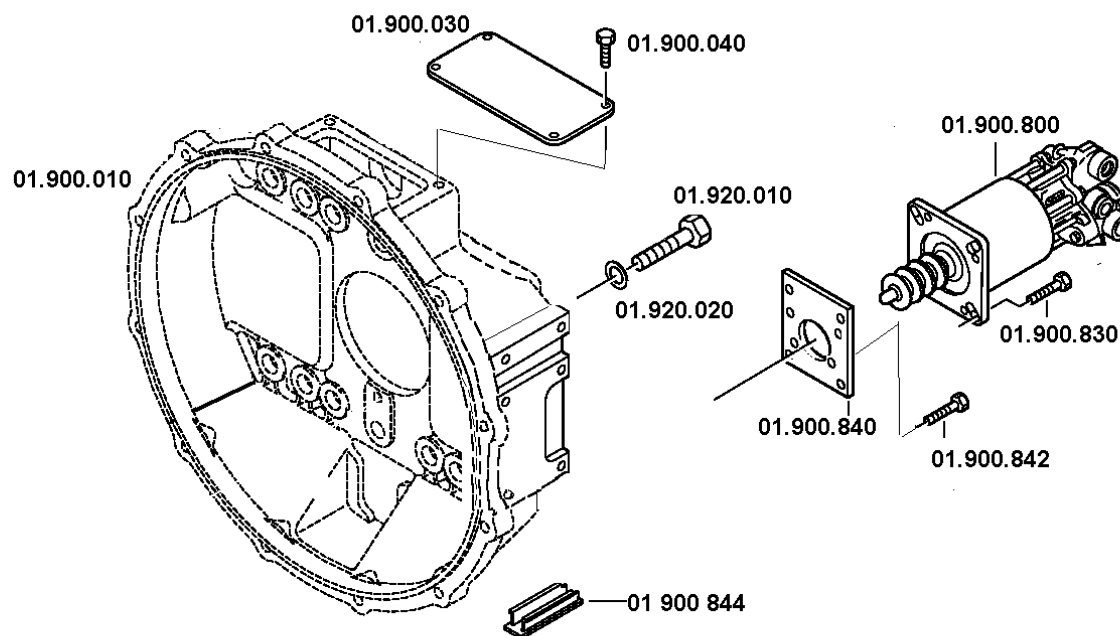

parts list: 1295 095 074

figure: 0095 900 001

8S-1350 / OD * LL* D-L H-H * KAMAZ / RUS

CLUTCH HOUSING

FIG.	QTY.	PART-NUMBER	DESCRIPTION	OPT.	MOD.NO.	TECHNICAL INFORMATION
010	1	0091 201 040	CLUTCH HOUSING			0091 201 040 (A0)
030	1	0501 317 373	COVER			
040	4		HEXAGON SCREW			M8X12 * ISO 4014 * 8.8 * A3C
	1	0636 015 388	HEXAGON SCREW			M8X12 * ISO 4017 * 8.8 * A3C
800	1	0501 006 570	CLUTCH CYLINDER			
830	4		HEXAGON SCREW			M8X14 * ISO 4017 * 8.8 * A3C
	1	0636 015 406	HEXAGON SCREW			M8X14 * ISO 4017/ZFB 988 * 8.8 A3C
840	1	6060 201 221	INTERM.PLATE			KPL.
842	4		HEXAGON SCREW			M8X20 * ISO 4017 * 8.8 * A3C
	1	0636 015 299	HEXAGON SCREW			M8X20 * ISO 4017/ZFB 988 * 8.8 A3C
844	1	0501 306 828	CLOSING COVER			0501 306 828 (A4)
010	1	0091 268 001	CLUTCH FORK			
020	1	6060 306 096	BEARING BRACKET			
030	1	0731 201 606	PIN			*IN 0731 201 607 (A2)
040	1	0635 285 060	ARTIC. ROLLER			GE25 UK-2RS 25x42x20 FA.ELGES
050	2	0630 502 023	RETAINING RING			42X1,75 DIN 472
060	2	0501 315 198	SEALING RING			32 X 42 X5 FA.CFW.
070	2	6060 306 087	SEALING WASHER			6060 306 087 (A3)
080	2	0630 501 020	RETAINING RING			25X1,2 DIN 471
010	1		HEXAGON SCREW			M12X35*DIN 933 * 8.8 * A3C
/010	1	0636 011 335	HEXAGON SCREW			M12X35*DIN 933 * 8.8 * A3C
/020	1	0630 001 049	WASHER			13 DIN 125 AUSG.9 200 HV A3C
024	7		HEXAGON SCREW			M18X1,5X70 * ISO 8765 * 8.8 * A3C
/010	1	0636 020 407	HEXAGON SCREW			M18X1,5X70 * ISO 8765 * 8.8 * A3C
/020	1	0630 001 021	WASHER			19 DIN 125 200HV AUSG.90-
026	1		HEXAGON SCREW			M18X1,5X145 * ISO 8765 * 8.8 * A3C
/010	1	0636 020 413	HEXAGON SCREW			M 18X1,5X145 * ISO 8765 * 8.8 * A3C
/020	1	0630 001 021	WASHER			19 DIN 125 200HV AUSG.90-

parts list: 1295 095 074
figure: 0095 031 001

8S-1350 / OD * LL * D-L H-H * KAMAZ / RUS
GP HOUSING

*depending on parts list n°.

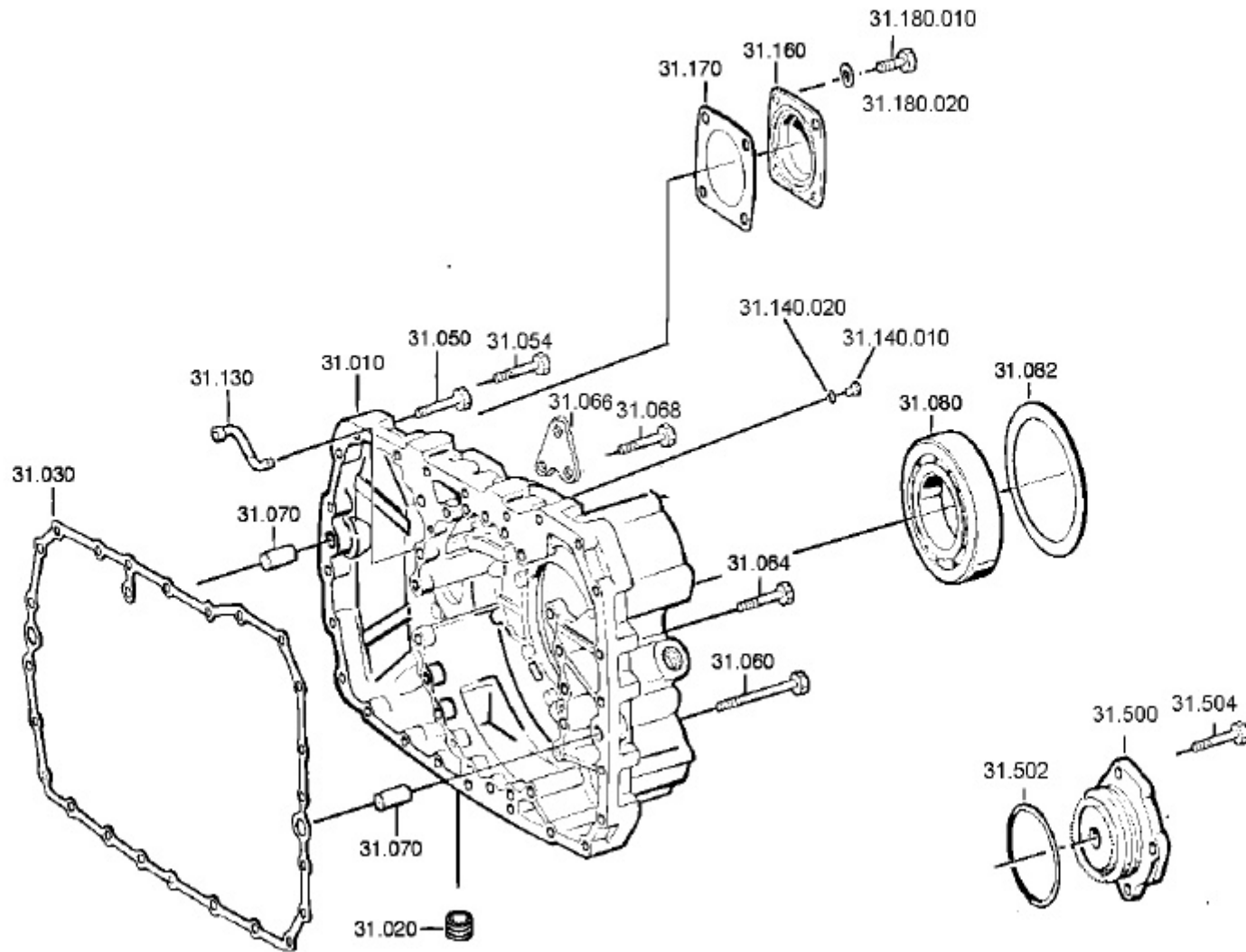

parts list: 1295 095 074
figure: 0095 031 002

8S-1350 / OD * LL * D-L H-H * KAMAZ / RUS
COVER

*depending on parts list n°.

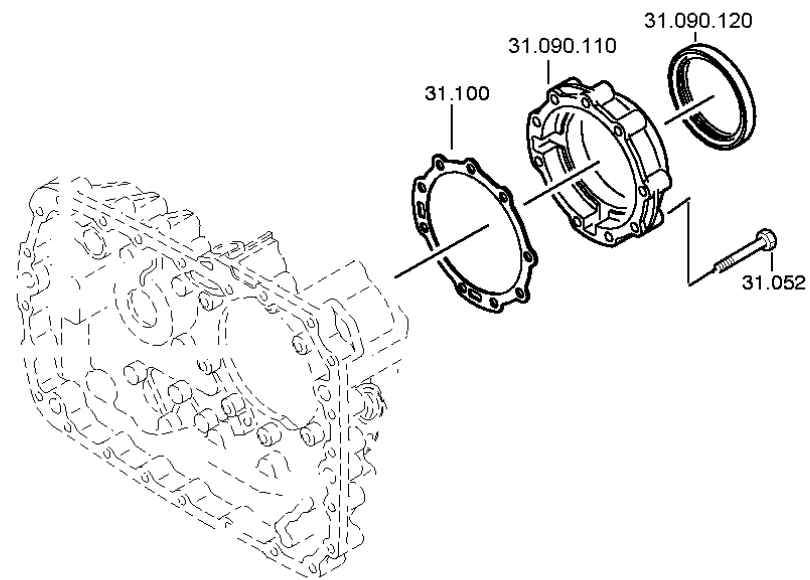

parts list: 1295 095 074
figure: 0095 031 001
0095 031 002

8S-1350 / OD * LL* D-L H-H * KAMAZ / RUS
GP HOUSING
COVER

FIG.	QTY.	PART-NUMBER	DESCRIPTION	OPT.	MOD.NO.	TECHNICAL INFORMATION
010	1	0091 301 138	HOUSING			
020	1		SCREW PLUG			M24X1,5 * 50,0 N.M
	1	0736 303 005	SCREW PLUG			M24X1,5
030	1	1313 301 037	GASKET			1313 301 037 (A1)
050	19		HEXAGON SCREW			M10X50 * DIN 931 * 8.8
	19	0636 010 168	HEXAGON SCREW			M10X50 * DIN 931 * 8.8
052	9		HEXAGON SCREW			M10X50 * DIN 931 * 8.8
	9	0636 010 168	HEXAGON SCREW			M10X50 * DIN 931 * 8.8
054	2		HEXAGON SCREW			M10X50 * DIN 931 * 8.8
	1	0636 010 168	HEXAGON SCREW			M10X50 * DIN 931 * 8.8
060	2		HEXAGON SCREW			M10X90 * DIN 931 * 8.8
	2	0636 010 190	HEXAGON SCREW			M10X90 * DIN 931 * 8.8
064	1		HEXAGON SCREW			M10X50 SK * DIN 931* 8.8
	1	0636 010 494	HEXAGON SCREW			M10X50 SK * DIN 931* 8.8
066	1	0091 301 115	SUPPORT PLATE GEAR SHIFT			0091 301 115 (A3)
068	2		HEXAGON SCREW			M10X55 * DIN 931 * 8.8
	2	0636 010 172	HEXAGON SCREW			M10X55 * DIN 931 * 8.8
070	2	0731 201 459	CYLINDER PIN			*IN 0731 201 458 (A1)
080	1	0750 116 002	BALL BEARING			WTB 90X60X30
082	1		SHIM			A=0,20-0,60 (THICKNESS RANGE :0,10MM)
/010	1	0730 003 515	SHIM			S=0,60 *IN 4005 302 064(A2)
/020	1	4005 302 034	SHIM			S=0,50 *IN 4005 302 064(A2)
/030	1	0730 100 115	SHIM			S=0,30 *IN 4005 302 064(A2)
/040	1	0730 100 846	SHIM			S=0,40 *IN 4005 302 064(A2)
/050	1	0730 100 116	SHIM			S=0,20 *IN 4005 302 064(A2)
090	1	0091 231 002	COVER			KPL.
/110	1	0091 301 144	COVER		57841	*IN 0091 301 143
/120	1	0750 111 341	SHAFT SEAL			105X130X12 WTB
100	1	1313 301 036	GASKET			1313 301 036 (A2)

parts list: 1295 095 074
figure: 0095 031 001
0095 031 002

8S-1350 / OD * LL* D-L H-H * KAMAZ / RUS
GP HOUSING
COVER

FIG.	QTY.	PART-NUMBER	DESCRIPTION	OPT.	MOD.NO.	TECHNICAL INFORMATION
130	1	1296 301 008	SPRAY TUBE			1296 301 008
140	1		SCREW PLUG			M10X1* 25,0 N.M * SEALING RING
/010	1	0636 302 053	SCREW PLUG			M 10X1 DIN 908 ST A3C
/020	1	0634 801 013	SEALING RING			A 10X14 DIN 7603 AL
160	1	0091 308 115	COVER		57183	*IN 0091 308 114
170	1	1238 308 201	GASKET			*IN 1238 308 202 (A2)
180	4		HEXAGON SCREW			M12X20 * DIN 933 8.8
/010	4	0636 016 005	HEXAGON SCREW			M12X20 DIN 933 / ZFB 988 8.8
/020	4	0630 302 021	WASHER			B12 DIN 137 FST
500	1	0091 331 002	CLOSING COVER			EN-GJL-200
502	1	0634 313 671	O-RING			80X3 ZFN744 ACM-80-10
504	4	0636 015 084	HEXAGON SCREW			M8X22 ISO 4017 8.8

parts list: 1295 095 074
figure: 0095 032 001

8S-1350 / OD * LL * D-L H-H * KAMAZ / RUS
PLANETARY DRIVE

*depending on parts list n°.

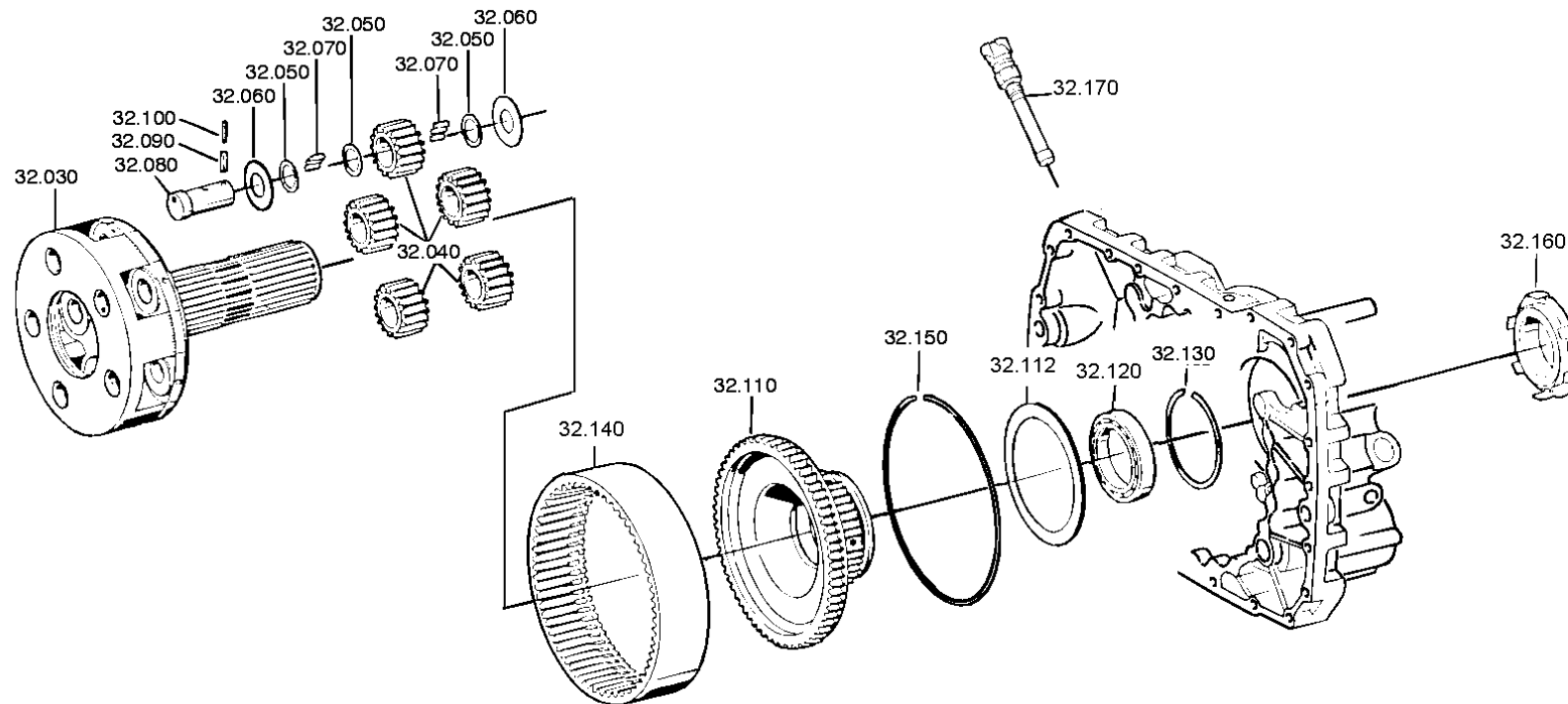

parts list: 1295 095 074
figure: 0095 032 002

8S-1350 / OD * LL * D-L H-H * KAMAZ / RUS
PLANETARY DRIVE

*depending on parts list n°.

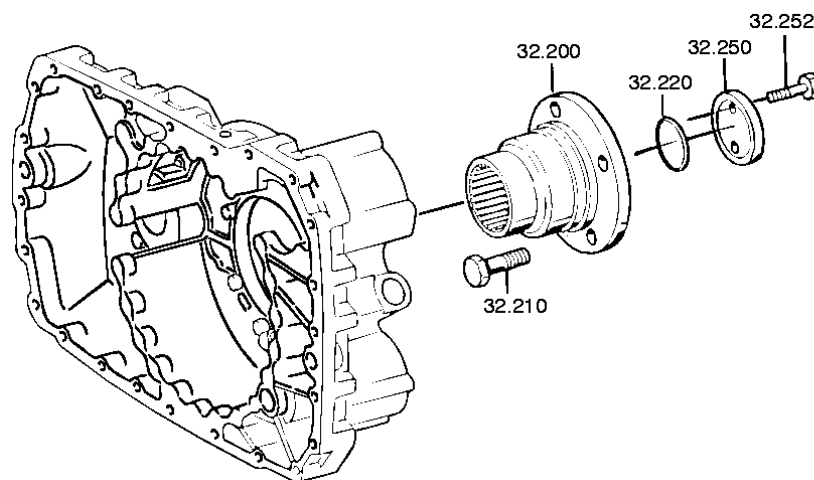

parts list: 1295 095 074
figure: 0095 032 001
0095 032 002

8S-1350 / OD * LL* D-L H-H * KAMAZ / RUS
PLANETARY DRIVE
FLANGE

FIG.	QTY.	PART-NUMBER	DESCRIPTION	OPT.	MOD.NO.	TECHNICAL INFORMATION
030	1	0091 232 022	PLANET.CARRIER			KPL
040	1	1297 232 023	GEAR SET			KPL
050	15	0730 103 846	INTERM.WASHER			A=1,00 *IN 0730 105 951 (A2)
060	10	0501 306 212	SHIM			*IN 0501 304 086 (A2)
070	120	0750 119 109	ROLLER			WTB 10,0X16,8
080	5	1297 332 109	PLANET.SHAFT			
090	5	0631 329 050	SLOT.PIN			5X24 ISO 8752 ST
100	5	0631 329 017	SLOT.PIN			3X24 ISO 8752 ST
110	1	0091 332 022	DIFFERENTIAL GEAR		57838	*IN 0091 332 044
112	1		INTERMEDIATE RING			WTB GGG60 /STAHL
	1	1297 332 122	INTERMEDIATE RING			
	1	1297 332 002	INTERMEDIATE RING			1297 332 002 (A2)
120	1	0750 116 165	BALL ROLLER			WTB 80,0X110,0X16,0
130	1		SNAP RING			A=2,00-2,50 (THICKNESS RANGE:0,10MM)
	1	0730 513 755	SNAP RING			A=2,50 *IN 0730 513 754 (A2)
	1	0730 513 756	SNAP RING			A=2,40 *IN 0730 513 754 (A2)
	1	0730 513 757	SNAP RING			A=2,30 *IN 0730 513 754 (A2)
	1	0730 513 758	SNAP RING			A=2,20 *IN 0730 513 754 (A2)
	1	0730 513 759	SNAP RING			A=2,10 *IN 0730 513 754 (A2)
	1	0730 513 760	SNAP RING			A=2,00 *IN 0730 513 754 (A2)
140	1	0091 332 048	RING GEAR		57837	*IN 091 332 047
150	1	0730 505 055	RETAINING RING			*IN 0730 505 052 (A2)
168	1		PULSE WASHER			KPL WTB
	1	0091 338 045	PULSE WASHER	X		*IN 0091 338 043 (A2)
	1	0091 338 042	PULSE WASHER	X		*IN 0091 338 043 (A2)
170	1	0501 208 795	PULSE SENSOR			*IN 0501 208 790 (A1) KPL
200	1	0091 338 063	OUTPUT FLANGE		57842	*IN 0091 338 062
210	4		HEXAGON SCREW			M14X1,5X50 DIN 960 10.9
	4	0636 020 211	HEXAGON SCREW			M14X1,5X50 DIN 960 10,9

parts list: 1295 095 074
 figure: 0095 032 001
 0095 032 002

8S-1350 / OD * LL* D-L H-H * KAMAZ / RUS
 PLANETARY DRIVE
 FLANGE

FIG.	QTY.	PART-NUMBER	DESCRIPTION	OPT.	MOD.NO.	TECHNICAL INFORMATION
220	1	0634 314 015	O-RING			68X4 ZFN 744 ACM-70-10
250	1	1295 332 051	THRUST WASHER			*IN 1295 332 063 (A2)
252	2		HEXAGON SCREW			M12X60 DIN 931 10.9 A3C
	2	0636 011 540	HEXAGON SCREW			M12X60 DIN 931 10.9 A3C

parts list: 1295 095 074
figure: 0095 033 001

8S-1350 / OD * LL * D-L H-H * KAMAZ / RUS
SYNCHRONIZER

*depending on parts list n°.

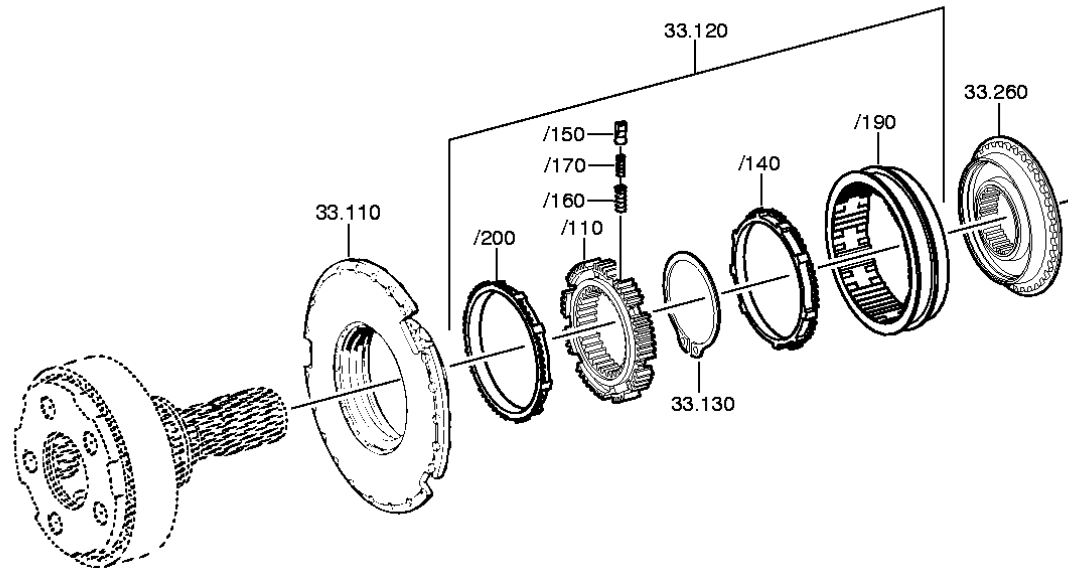

parts list: 1295 095 074

8S-1350 / OD * LL* D-L H-H * KAMAZ / RUS

figure: 0095 033 001

SYNCHRONIZER

FIG.	QTY.	PART-NUMBER	DESCRIPTION	OPT.	MOD.NO.	TECHNICAL INFORMATION
110	1	1296 233 006	CLUTCH BODY			1296 233 006 (A1)
120	1	1295 233 033	SYNCHRONIZER			KPL.MOLYB * FL PROF.75/80
/110	1	1296 333 002	SYNCHRO.BODY			*IN 1296 333 014 (A1)
/140	1		SYNCHRO.RING			WTB*SINT/SCHMIEDE*MOLYB
	1	1296 333 044	SYNCHRO.RING	X		1296 333 044 (A1)
	1	1296 333 045	SYNCHRO.RING	X		1296 333 045 (A1)
/150	9	1240 304 278	PRESSURE PIECE			ZF-B119-167
/160	9	0732 040 385	COMPR.SPRING			0732 040 385 (A3)
/170	9	0732 040 386	COMPR.SPRING			0732 040 386 (A3)
/190	1	1296 333 023	SLIDING SLEEVE			1304 333 013 (A1)
/200	1		SYNCHRO.RING			WTB*SINT/SCHMIEDE*MOLYB
	1	1296 333 044	SYNCHRO.RING			1296 333 044 (A1)
	1	1296 333 045	SYNCHRO.RING			1296 333 045 (A1)
130	1		RETAINING RING			A=3,70 -4,00 (THICKNESS : 0,10MM) WTB
	1	0630 501 061	RETAINING RING			125X4 DIN 471
	1	0630 501 173	RETAININ R			125X3,9 DIN 471
	1	0630 501 174	RETAINING RING			125X3,8 DIN 471
	1	0630 501 175	RETAINING RING			125X3,7 DIN 471
260	1	1313 233 001	CLUTCH BODY			KPL. *IN 1313 233 004 (A2)

parts list: 1295 095 074
figure: 0095 034 001

8S-1350 / OD * LL * D-L H-H * KAMAZ / RUS
GP SHIFT SYSTEM

*depending on parts list n°.

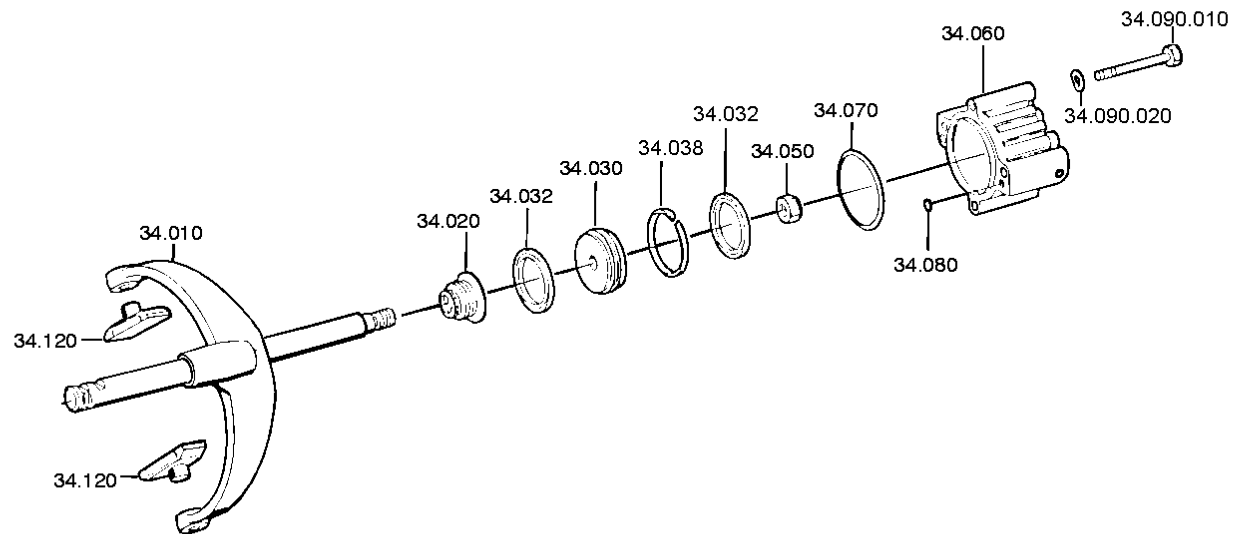

parts list: 1295 095 074
figure: 0095 034 002

8S-1350 / OD * LL * D-L H-H * KAMAZ / RUS
CONN.PARTS

*depending on parts list n°.

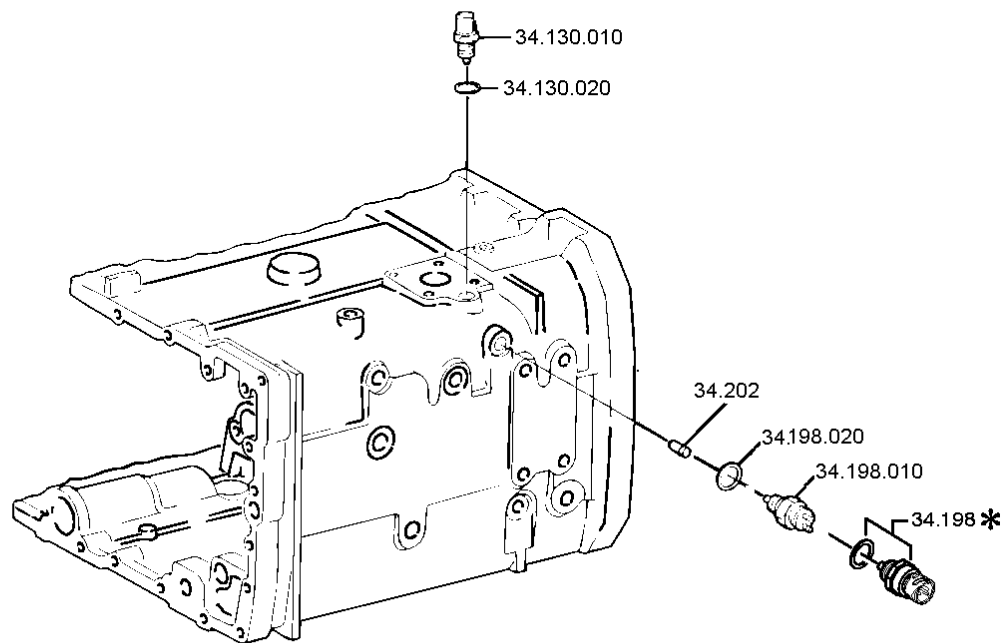

parts list: 1295 095 074
 figure: 0095 034 001
 0095 034 002

8S-1350 / OD * LL* D-L H-H * KAMAZ / RUS
 GP SHIFT SYSTEM
 CONN. PARTS

FIG.	QTY.	PART-NUMBER	DESCRIPTION	OPT.	MOD.NO.	TECHNICAL INFORMATION
010	1	0091 234 008	GEAR CHANGE BAR			KPL.
020	1	0750 112 034	FLANGE PACKING			WTB 25X38X14,2
030	1	1296 334 039	PISTON			1296 334 039 (A2)
032	2	0734 317 150	GROOVED RING			80X90X4,8 FA.KACO
036	1	0750 112 066	GUIDE RING			WTB
050	1		LOCKING NUT			M16X1,5 * DIN 980 10 A3C
	1	0637 011 574	LOCKING NUT			M16X1,5 * DIN 980 10 A3C
060	1	1295 334 075	CYLINDER			
070	1	0634 314 019	O-RING			94X3 ZFN 744 ACM - 70-10
080	1	0634 314 020	O-RING			8X2 ZFN 744 ACM - 70-10
086	4		HEX CAP SCREW			M10X80 * DIN 931 * 8.8 * A3C
/010	4	0636 010 550	HEX CAP SCREW			M10X80 * DIN 931 * 8.8 * A3C
/020	1	0630 302 091	SPRING WASHER			B10 DIN 137 FST FE/ZN8C
120	2	1296 334 004	SLIDING PAD			*IN 1295 334 065(A2)
130	1		DETENT PLUNGER			105 N * 65 N.M
/010	1	1313 207 004	DETENT PLUNGER			KPL *IN 1313 207 001 (A2)
/020	1	0634 801 050	SEALING RING			A16X22 DIN 7603 CU
198	1		SWITCH			SWITCH * 45,0 N.M * SEALING RING
/010	1	0501 210 058	SWITCH			KPL.
/020	1	0634 801 062	SEALING RING			A18X24 DIN 7603 AL
202	1	1295 212 006	PIN			KPL.
	1	0731 208 056	PIN			*IN 0731 208 091 (A2)
	1	0630 505 524	SNAP RING			A 8 DIN 7993

parts list: 1295 095 074

8S-1350 / OD * LL* D-L H-H * KAMAZ / RUS

figure:

REPAIRS SET

FIG.	QTY.	PART-NUMBER	DESCRIPTION	OPT.	MOD.NO.	TECHNICAL INFORMATION
	1	0091 298 001	COMPLETE REPAIR SET			SHAFT SEALS AND GASKETS